

---

DESPIECE TECNICO

---

**Lavavajillas  
Lavevaisselle  
Dishwasher  
Geschirrspüler  
Lavastoviglie**

**Modelos:**

**FI-72**

*Junio 2003 June*



**Fagor Industrial**

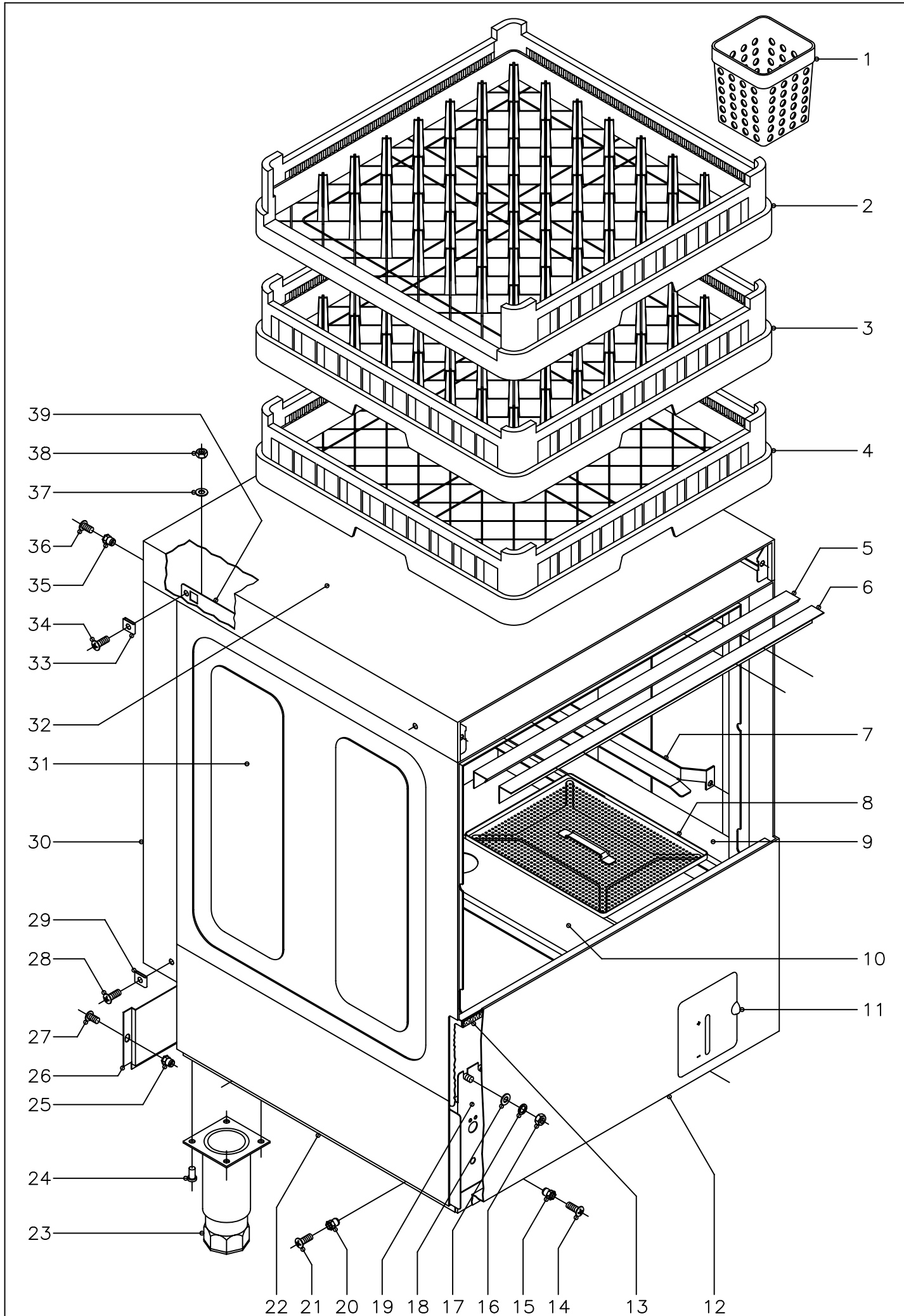

N plano  
C-1390

Firma  
*[Signature]*

Fecha  
6-2003

Aparato MUEBLE  
LAVAVAJILLAS FI-72

Lamina  
1

Fagor Industrial S.Coop. **FAGOR**  
Onate

| MOD. |         | LAVAVAJILLAS FRONTAL            |       | ZONA  | MUEBLE Y CESTILLOS |  |  |  |  |  |  | PLANO | C-1390 |
|------|---------|---------------------------------|-------|-------|--------------------|--|--|--|--|--|--|-------|--------|
| ITEM | CODIGO  | DENOMINACION                    | TEXTO | FI-72 |                    |  |  |  |  |  |  |       | NOTAS  |
| 1    | Z655314 | Cestillo cubiertos              |       | 4     |                    |  |  |  |  |  |  |       |        |
| 2    | Z685302 | Cestillo bandejas CB-7 completo |       | 1     |                    |  |  |  |  |  |  |       |        |
| 3    | Z655302 | Cestillo platos CP-16/18        |       | 1     |                    |  |  |  |  |  |  |       |        |
| 4    | Z655301 | Cestillo base CT-10             |       | 1     |                    |  |  |  |  |  |  |       |        |
| 5    | Z200315 | Perfil caja                     |       | 1     |                    |  |  |  |  |  |  |       |        |
| 6    | Z200309 | Escuadra sujecion perfil        |       | 1     |                    |  |  |  |  |  |  |       |        |
| 7    | Z200305 | Guia cestillo derecha           |       | 1     |                    |  |  |  |  |  |  |       |        |
| s/n  | Z200306 | Guia cestillo izquierda         |       | 1     |                    |  |  |  |  |  |  |       |        |
| 8    | Z210801 | Bandeja filtro                  |       | 4     |                    |  |  |  |  |  |  |       |        |
| 9    | Z210805 | Soporte derecho bandejas        |       | 1     |                    |  |  |  |  |  |  |       |        |
| s/n  | Z210806 | Soporte izquierdo bandejas      |       | 1     |                    |  |  |  |  |  |  |       |        |
| 10   | Z210804 | Soporte central bandejas        |       | 1     |                    |  |  |  |  |  |  |       |        |
|      | Q232040 | Arandela plana A-6              |       | 8     |                    |  |  |  |  |  |  |       |        |
|      | Q162040 | Tuerca exagonal M-6             |       | 8     |                    |  |  |  |  |  |  |       |        |
| 11   | Z212902 | Puerta deposito completa        |       | 1     |                    |  |  |  |  |  |  |       |        |
| s/n  | Z212906 | Eje puerta                      |       | 1     |                    |  |  |  |  |  |  |       |        |
| s/n  | Q352001 | Pasador de aletas Ø2x15         |       | 2     |                    |  |  |  |  |  |  |       |        |
| 12   | Z262911 | Panel frontal                   |       | 1     |                    |  |  |  |  |  |  |       |        |
| 13   | Z200313 | Perfil goma esponjosa           |       | 1     |                    |  |  |  |  |  |  |       |        |
| 14   | Q152004 | Tornillo aplastado M-5x13       |       | 2     |                    |  |  |  |  |  |  |       |        |
| 15   | Q221342 | Remache exagonal M-5            |       | 2     |                    |  |  |  |  |  |  |       |        |
| 16   | Q162040 | Tuerca exagonal M-6             |       | 8     |                    |  |  |  |  |  |  |       |        |
| 17   | Q262040 | Arandela muelle A-6             |       | 8     |                    |  |  |  |  |  |  |       |        |
| 18   | Q232040 | Arandela plana A-6              |       | 8     |                    |  |  |  |  |  |  |       |        |
| 19   | Z260101 | Armazon completo                |       | 1     |                    |  |  |  |  |  |  |       |        |
| 20   | Q221342 | Remache exagonal M-5            |       | 4     |                    |  |  |  |  |  |  |       |        |
| 21   | Q152004 | Tornillo aplastado M-5x13       |       | 4     |                    |  |  |  |  |  |  |       |        |
| 22   | Z262903 | Panel lateral izquierdo         |       | 1     |                    |  |  |  |  |  |  |       |        |
| s/n  | Z262902 | Panel lateral derecho           |       | 1     |                    |  |  |  |  |  |  |       |        |

| MOD. |         | LAVAVAJILLAS FRONTAL      |       |       | ZONA | MUEBLE Y CESTILLOS |  |  |  |  |  |  | PLANO | C-1390 |
|------|---------|---------------------------|-------|-------|------|--------------------|--|--|--|--|--|--|-------|--------|
| ITEM | CODIGO  | DENOMINACION              | TEXTO | FI-72 |      |                    |  |  |  |  |  |  |       | NOTAS  |
| 23   | X260150 | Pata regulable            |       | 4     |      |                    |  |  |  |  |  |  |       |        |
| 24   | Q411304 | Remache avibulb Ø4,8      |       | 12    |      |                    |  |  |  |  |  |  |       |        |
| 25   | Q221342 | Remache exagonal M-5      |       | 2     |      |                    |  |  |  |  |  |  |       |        |
| 26   | Z262905 | Panel posterior inferior  |       | 1     |      |                    |  |  |  |  |  |  |       |        |
| 27   | Q152004 | Tornillo aplastado M-5x13 |       | 2     |      |                    |  |  |  |  |  |  |       |        |
| 28   | Q152004 | Tornillo aplastado M-5x13 |       | 2     |      |                    |  |  |  |  |  |  |       |        |
| 29   | Q221012 | Tuerca rapida M-5         |       | 2     |      |                    |  |  |  |  |  |  |       |        |
| 30   | Z262904 | Panel posterior           |       | 1     |      |                    |  |  |  |  |  |  |       |        |
| 31   | Z260325 | Caja soldada              |       | 1     |      |                    |  |  |  |  |  |  |       |        |
| 32   | Z202906 | Tapa                      |       | 1     |      |                    |  |  |  |  |  |  |       |        |
| 33   | Q221012 | Tuerca rapida M-5         |       | 4     |      |                    |  |  |  |  |  |  |       |        |
| 34   | Q152004 | Tornillo aplastado M-5x13 |       | 4     |      |                    |  |  |  |  |  |  |       |        |
| 35   | Q221342 | Remache exagonal M-5      |       | 2     |      |                    |  |  |  |  |  |  |       |        |
| 36   | Q152004 | Tornillo aplastado M-5x13 |       | 2     |      |                    |  |  |  |  |  |  |       |        |
| 37   | Q232040 | Arandela plana A-6        |       | 4     |      |                    |  |  |  |  |  |  |       |        |
| 38   | Q162040 | Tuerca exagonal M-6       |       | 4     |      |                    |  |  |  |  |  |  |       |        |
| 39   | Z200307 | Escuadra amarre tapa      |       | 2     |      |                    |  |  |  |  |  |  |       |        |
|      |         |                           |       |       |      |                    |  |  |  |  |  |  |       |        |
|      |         |                           |       |       |      |                    |  |  |  |  |  |  |       |        |
|      |         |                           |       |       |      |                    |  |  |  |  |  |  |       |        |
|      |         |                           |       |       |      |                    |  |  |  |  |  |  |       |        |
|      |         |                           |       |       |      |                    |  |  |  |  |  |  |       |        |
|      |         |                           |       |       |      |                    |  |  |  |  |  |  |       |        |
|      |         |                           |       |       |      |                    |  |  |  |  |  |  |       |        |
|      |         |                           |       |       |      |                    |  |  |  |  |  |  |       |        |
|      |         |                           |       |       |      |                    |  |  |  |  |  |  |       |        |
|      |         |                           |       |       |      |                    |  |  |  |  |  |  |       |        |
|      |         |                           |       |       |      |                    |  |  |  |  |  |  |       |        |

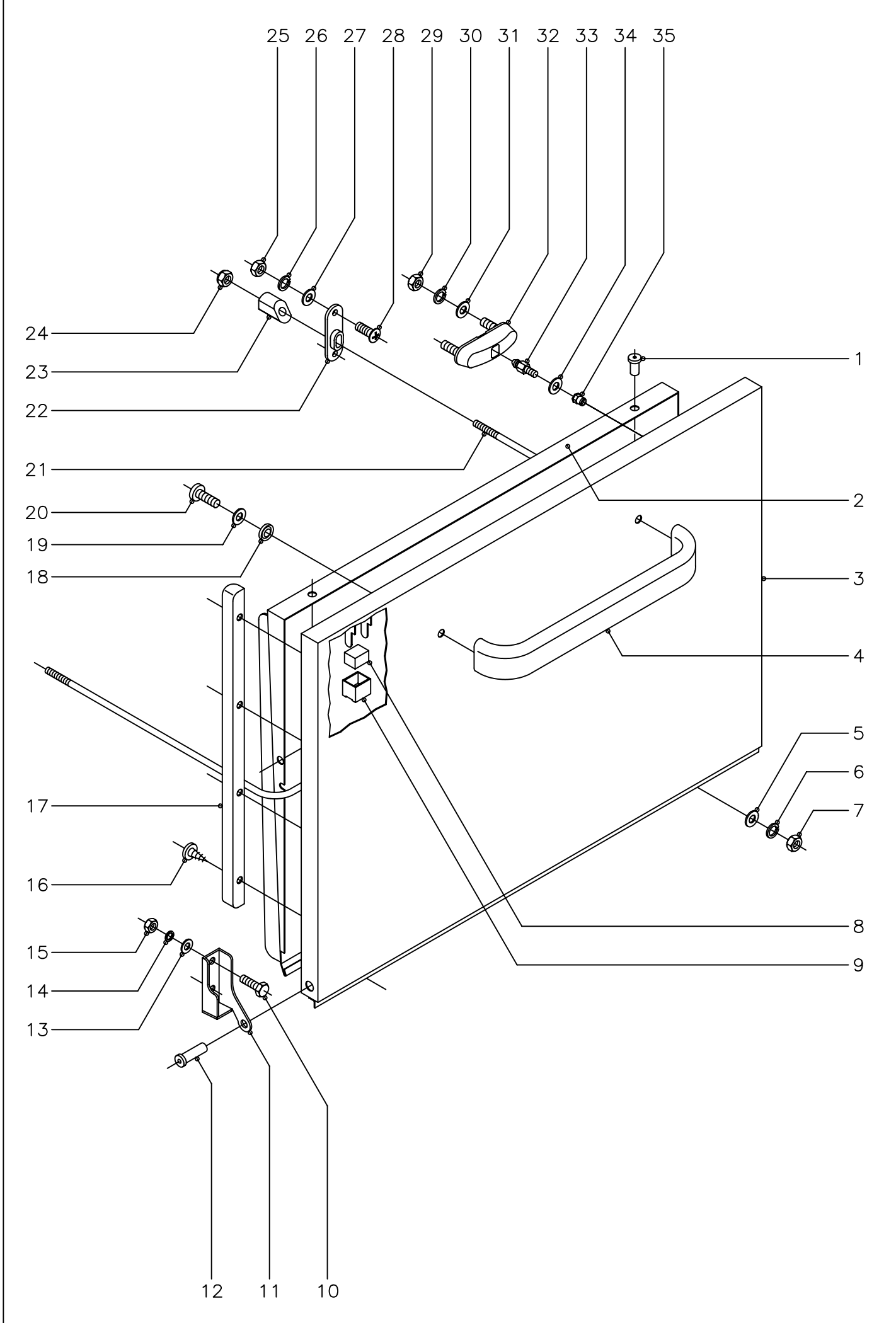

|                   |  |                 |   |             |  |
|-------------------|--|-----------------|---|-------------|--|
| N plano<br>C-1391 | Firma<br> | Fecha<br>6-2003 | Aparato<br>PUERTA<br>LAVAVAJILLAS FI-72 | Lamina<br>2 | Fagor Industrial S.Coop. <b>FAGOR</b><br>Onate |
|-------------------|--|-----------------|---|-------------|--|

| MOD. |         | LAVAVAJILLAS FRONTAL      |       | ZONA  | PUERTA |  |  |  |  |  |  | PLANO | C-1391 |
|------|---------|---------------------------|-------|-------|--------|--|--|--|--|--|--|-------|--------|
| ITEM | CODIGO  | DENOMINACION              | TEXTO | FI-72 |        |  |  |  |  |  |  |       | NOTAS  |
| 1    | Q412000 | Remache tubular Ø4x8      |       | 4     |        |  |  |  |  |  |  |       |        |
| 2    | Z260533 | Contrapuerta soldada      |       | 1     |        |  |  |  |  |  |  |       |        |
| 3    | Z260531 | Puerta soldada            |       | 1     |        |  |  |  |  |  |  |       |        |
| 4    | Z200512 | Asa puerta                |       | 1     |        |  |  |  |  |  |  |       |        |
| 5    | Q232030 | Arandela plana A-5        |       | 2     |        |  |  |  |  |  |  |       |        |
| 6    | Q262030 | Arandela muelle A-5       |       | 2     |        |  |  |  |  |  |  |       |        |
| 7    | Q162030 | Tuerca exagonal M-5       |       | 2     |        |  |  |  |  |  |  |       |        |
| 8    | Z200506 | Iman                      |       | 1     |        |  |  |  |  |  |  |       |        |
| 9    | Z200507 | Protector iman            |       | 1     |        |  |  |  |  |  |  |       |        |
| 10   | Q012042 | Tornillo exagonal M-6x15  |       | 4     |        |  |  |  |  |  |  |       |        |
| 11   | Z400514 | Bisagra izquierda         |       | 1     |        |  |  |  |  |  |  |       |        |
| s/n  | Z400515 | Bisagra derecha           |       | 1     |        |  |  |  |  |  |  |       |        |
| 12   | Z400516 | Eje puerta                |       | 2     |        |  |  |  |  |  |  |       |        |
| 13   | Q232040 | Arandela plana A-6        |       | 4     |        |  |  |  |  |  |  |       |        |
| 14   | Q262040 | Arandela muelle A-6       |       | 4     |        |  |  |  |  |  |  |       |        |
| 15   | Q162040 | Tuerca exagonal M-6       |       | 4     |        |  |  |  |  |  |  |       |        |
| 16   | Q082005 | Tornillo chapa 4,2x13     |       | 8     |        |  |  |  |  |  |  |       |        |
| 17   | Z260508 | Marco puerta              |       | 2     |        |  |  |  |  |  |  |       |        |
| 18   | Q308002 | Arandela dubo A-6         |       | 2     |        |  |  |  |  |  |  |       |        |
| 19   | Q232040 | Arandela plana A-6        |       | 2     |        |  |  |  |  |  |  |       |        |
| 20   | Q032041 | Tornillo alomado M-6x10   |       | 2     |        |  |  |  |  |  |  |       |        |
| 21   | Z260506 | Varilla tensor            |       | 1     |        |  |  |  |  |  |  |       |        |
| 22   | Z200310 | Soporte tensor            |       | 2     |        |  |  |  |  |  |  |       |        |
| 23   | Z200522 | Tensor de puerta          |       | 2     |        |  |  |  |  |  |  |       |        |
| 24   | Q222012 | Tuerca autoblocante M-6   |       | 2     |        |  |  |  |  |  |  |       |        |
| 25   | Q162030 | Tuerca exagonal M-5       |       | 4     |        |  |  |  |  |  |  |       |        |
| 26   | Q262030 | Arandela muelle A-5       |       | 4     |        |  |  |  |  |  |  |       |        |
| 27   | Q232030 | Arandela plana A-5        |       | 4     |        |  |  |  |  |  |  |       |        |
| 28   | Q152004 | Tornillo aplastado M-5x13 |       | 4     |        |  |  |  |  |  |  |       |        |

|      |                      |      |        |       |        |
|------|----------------------|------|--------|-------|--------|
| MOD. | LAVAVAJILLAS FRONTAL | ZONA | PUERTA | PLANO | C-1391 |
|------|----------------------|------|--------|-------|--------|

| ITEM | CODIGO  | DENOMINACION            | TEXTO | FI-72 |  |  |  |  |  |  |  |  |  |  | NOTAS |
|------|---------|-------------------------|-------|-------|--|--|--|--|--|--|--|--|--|--|-------|
| 29   | Q222012 | Tuerca autoblocante M-6 |       | 4     |  |  |  |  |  |  |  |  |  |  |       |
| 30   | Q262040 | Arandela muelle A-6     |       | 4     |  |  |  |  |  |  |  |  |  |  |       |
| 31   | Q232040 | Arandela plana A-6      |       | 4     |  |  |  |  |  |  |  |  |  |  |       |
| 32   | Z200607 | Conjunto cierre puerta  |       | 2     |  |  |  |  |  |  |  |  |  |  |       |
| 33   | Z200601 | Enganche cierre         |       | 2     |  |  |  |  |  |  |  |  |  |  |       |
| 34   | Q232030 | Arandela plana A-5      |       | 2     |  |  |  |  |  |  |  |  |  |  |       |
| 35   | Q222011 | Remache exagonal M-5    |       | 2     |  |  |  |  |  |  |  |  |  |  |       |
|      |         |                         |       |       |  |  |  |  |  |  |  |  |  |  |       |
|      |         |                         |       |       |  |  |  |  |  |  |  |  |  |  |       |
|      |         |                         |       |       |  |  |  |  |  |  |  |  |  |  |       |
|      |         |                         |       |       |  |  |  |  |  |  |  |  |  |  |       |
|      |         |                         |       |       |  |  |  |  |  |  |  |  |  |  |       |
|      |         |                         |       |       |  |  |  |  |  |  |  |  |  |  |       |
|      |         |                         |       |       |  |  |  |  |  |  |  |  |  |  |       |
|      |         |                         |       |       |  |  |  |  |  |  |  |  |  |  |       |
|      |         |                         |       |       |  |  |  |  |  |  |  |  |  |  |       |
|      |         |                         |       |       |  |  |  |  |  |  |  |  |  |  |       |
|      |         |                         |       |       |  |  |  |  |  |  |  |  |  |  |       |
|      |         |                         |       |       |  |  |  |  |  |  |  |  |  |  |       |
|      |         |                         |       |       |  |  |  |  |  |  |  |  |  |  |       |
|      |         |                         |       |       |  |  |  |  |  |  |  |  |  |  |       |
|      |         |                         |       |       |  |  |  |  |  |  |  |  |  |  |       |
|      |         |                         |       |       |  |  |  |  |  |  |  |  |  |  |       |
|      |         |                         |       |       |  |  |  |  |  |  |  |  |  |  |       |
|      |         |                         |       |       |  |  |  |  |  |  |  |  |  |  |       |
|      |         |                         |       |       |  |  |  |  |  |  |  |  |  |  |       |
|      |         |                         |       |       |  |  |  |  |  |  |  |  |  |  |       |
|      |         |                         |       |       |  |  |  |  |  |  |  |  |  |  |       |
|      |         |                         |       |       |  |  |  |  |  |  |  |  |  |  |       |
|      |         |                         |       |       |  |  |  |  |  |  |  |  |  |  |       |
|      |         |                         |       |       |  |  |  |  |  |  |  |  |  |  |       |
|      |         |                         |       |       |  |  |  |  |  |  |  |  |  |  |       |
|      |         |                         |       |       |  |  |  |  |  |  |  |  |  |  |       |
|      |         |                         |       |       |  |  |  |  |  |  |  |  |  |  |       |
|      |         |                         |       |       |  |  |  |  |  |  |  |  |  |  |       |
|      |         |                         |       |       |  |  |  |  |  |  |  |  |  |  |       |
|      |         |                         |       |       |  |  |  |  |  |  |  |  |  |  |       |
|      |         |                         |       |       |  |  |  |  |  |  |  |  |  |  |       |
|      |         |                         |       |       |  |  |  |  |  |  |  |  |  |  |       |
|      |         |                         |       |       |  |  |  |  |  |  |  |  |  |  |       |
|      |         |                         |       |       |  |  |  |  |  |  |  |  |  |  |       |
|      |         |                         |       |       |  |  |  |  |  |  |  |  |  |  |       |
|      |         |                         |       |       |  |  |  |  |  |  |  |  |  |  |       |
|      |         |                         |       |       |  |  |  |  |  |  |  |  |  |  |       |
|      |         |                         |       |       |  |  |  |  |  |  |  |  |  |  |       |
|      |         |                         |       |       |  |  |  |  |  |  |  |  |  |  |       |
|      |         |                         |       |       |  |  |  |  |  |  |  |  |  |  |       |
|      |         |                         |       |       |  |  |  |  |  |  |  |  |  |  |       |
|      |         |                         |       |       |  |  |  |  |  |  |  |  |  |  |       |

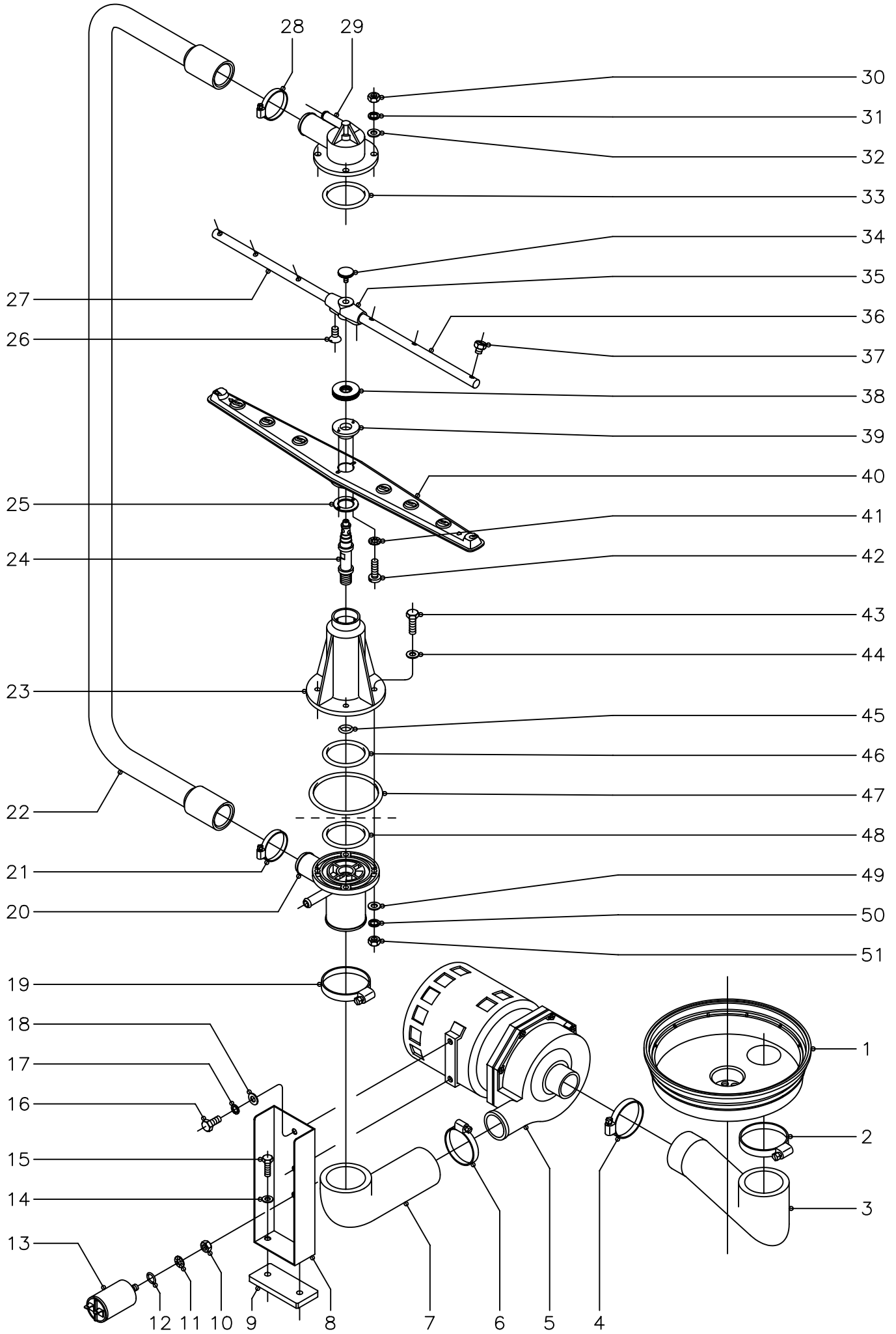

|                   |  |                 |   |             |  |
|-------------------|--|-----------------|---|-------------|--|
| N plano<br>C-1392 | Firma<br> | Fecha<br>6-2003 | Aparato<br>PARTE FUNCIONAL LAVADO<br>LAVAVAJILLAS FI-72 | Lamina<br>3 | Fagor Industrial S.Coop. <b>FAGOR</b> <br>Onate |
|-------------------|--|-----------------|---|-------------|--|



| MOD. |         | LAVAVAJILLAS FRONTAL               |       | ZONA  | PARTE FUNCIONAL LAVADO |  |  |  |  |  |  | PLANO | C-1392 |
|------|---------|------------------------------------|-------|-------|------------------------|--|--|--|--|--|--|-------|--------|
| ITEM | CODIGO  | DENOMINACION                       | TEXTO | FI-72 |                        |  |  |  |  |  |  |       | NOTAS  |
| 1    | Z200906 | Cubeta                             |       | 1     |                        |  |  |  |  |  |  |       |        |
| 2    | Q881324 | Abrazadera 50 - 70                 |       | 1     |                        |  |  |  |  |  |  |       |        |
| 3    | Z200904 | Codo aspiracion                    |       | 1     |                        |  |  |  |  |  |  |       |        |
| 4    | Q881307 | Abrazadera 40 - 60                 |       | 1     |                        |  |  |  |  |  |  |       |        |
| 5    | Z201011 | Bomba de lavado ( 230 V., 50 Hz. ) |       | 1     |                        |  |  |  |  |  |  |       |        |
| 5    | Z203511 | Bomba de lavado ( 230 V., 60 Hz. ) |       | 1     |                        |  |  |  |  |  |  |       |        |
|      | Z201081 | Conjunto junta y reten de bomba    |       | 1     |                        |  |  |  |  |  |  |       |        |
|      | Z201082 | Turbina 50 Hz. ( Ø 88 mm. )        |       | 1     |                        |  |  |  |  |  |  |       |        |
|      | Z203571 | Turbina 60 Hz. ( Ø 77 mm. )        |       | 1     |                        |  |  |  |  |  |  |       |        |
| 6    | Q881307 | Abrazadera 40 - 60                 |       | 1     |                        |  |  |  |  |  |  |       |        |
| 7    | Z200905 | Codo impulsion                     |       | 1     |                        |  |  |  |  |  |  |       |        |
| 8    | Z261001 | Soporte motobomba                  |       | 1     |                        |  |  |  |  |  |  |       |        |
| 9    | Z201003 | Base bomba lavado                  |       | 1     |                        |  |  |  |  |  |  |       |        |
| 10   | Q162050 | Tuerca exagonal M-8                |       | 1     |                        |  |  |  |  |  |  |       |        |
| 11   | Q242050 | Arandela abanico A-8               |       | 1     |                        |  |  |  |  |  |  |       |        |
| 12   | Q307048 | Junta torica Ø16,18xØ9,12xØ3,53    |       | 1     |                        |  |  |  |  |  |  |       |        |
| 13   | V321300 | Condensador 10mF.                  |       | 1     |                        |  |  |  |  |  |  |       |        |
| 14   | Q232030 | Arandela plana A-5                 |       | 2     |                        |  |  |  |  |  |  |       |        |
| 15   | Q012033 | Tornillo exagonal M-5x20           |       | 2     |                        |  |  |  |  |  |  |       |        |
| 16   | Q012041 | Tornillo exagonal M-6x10           |       | 2     |                        |  |  |  |  |  |  |       |        |
| 17   | Q262040 | Arandela muelle A-6                |       | 2     |                        |  |  |  |  |  |  |       |        |
| 18   | Q232040 | Arandela plana A-6                 |       | 2     |                        |  |  |  |  |  |  |       |        |
| 19   | Q881324 | Abrazadera 50 - 70                 |       | 1     |                        |  |  |  |  |  |  |       |        |
| 20   | Z200703 | Pasamuros                          |       | 1     |                        |  |  |  |  |  |  |       |        |
| 21   | Q881305 | Abrazadera 25 - 40                 |       | 1     |                        |  |  |  |  |  |  |       |        |
| 22   | Z260701 | Arbol de lavado                    |       | 1     |                        |  |  |  |  |  |  |       |        |
| 23   | Z200701 | Soporte distribuidor inferior      |       | 1     |                        |  |  |  |  |  |  |       |        |
| 24   | Z200704 | Eje central                        |       | 2     |                        |  |  |  |  |  |  |       |        |
| 25   | Z650711 | Amarre engancho distribuidor       |       | 2     |                        |  |  |  |  |  |  |       |        |

| MOD. |         | LAVAVAJILLAS FRONTAL             |       | ZONA  | PARTE FUNCIONAL LAVADO |  |  |  |  |  |  | PLANO | C-1392 |
|------|---------|----------------------------------|-------|-------|------------------------|--|--|--|--|--|--|-------|--------|
| ITEM | CODIGO  | DENOMINACION                     | TEXTO | FI-72 |                        |  |  |  |  |  |  |       | NOTAS  |
| 26   | Q152024 | Tornillo avellanado M-4x8        |       | 4     |                        |  |  |  |  |  |  |       |        |
| 27   | Z201902 | Rama aclarado izquierda          |       | 2     |                        |  |  |  |  |  |  |       |        |
| 28   | Q881305 | Abrazadera 25 - 40               |       | 1     |                        |  |  |  |  |  |  |       |        |
| 29   | Z200707 | Soporte distribuidor superior    |       | 1     |                        |  |  |  |  |  |  |       |        |
| 30   | Q162040 | Tuerca exagonal M-6              |       | 4     |                        |  |  |  |  |  |  |       |        |
| 31   | Q262040 | Arandela muelle A-6              |       | 4     |                        |  |  |  |  |  |  |       |        |
| 32   | Q232040 | Arandela plana A-6               |       | 4     |                        |  |  |  |  |  |  |       |        |
| 33   | Q307052 | Junta torica Ø60,83xØ50,17xØ5,33 |       | 1     |                        |  |  |  |  |  |  |       |        |
| 34   | Q152016 | Tornillo especial M-5x0,8        |       | 2     |                        |  |  |  |  |  |  |       |        |
| 35   | Z201903 | Soporte ramas aclarado           |       | 2     |                        |  |  |  |  |  |  |       |        |
| 36   | Z201901 | Rama aclarado derecha            |       | 2     |                        |  |  |  |  |  |  |       |        |
| 37   | Z211903 | Tobera aclarado                  |       | 12    |                        |  |  |  |  |  |  |       |        |
| 38   | Z200705 | Tuerca especial M-14x1           |       | 2     |                        |  |  |  |  |  |  |       |        |
| 39   | Z650704 | Eganche distribuidor             |       | 2     |                        |  |  |  |  |  |  |       |        |
| 40   | Z650716 | Distribuidor montado             |       | 2     |                        |  |  |  |  |  |  |       |        |
| 41   | Q242010 | Arandela abanico A-3             |       | 4     |                        |  |  |  |  |  |  |       |        |
| 42   | Q152015 | Tornillo alomado M-3x6           |       | 4     |                        |  |  |  |  |  |  |       |        |
| 43   | Q012046 | Tornillo exagonal M-6x40         |       | 4     |                        |  |  |  |  |  |  |       |        |
| 44   | Q306050 | Arandela fibra roja Ø11xØ6,2x1,5 |       | 4     |                        |  |  |  |  |  |  |       |        |
| 45   | Q307050 | Junta torica Ø19,18xØ13,94xØ2,62 |       | 1     |                        |  |  |  |  |  |  |       |        |
| 46   | Q307052 | Junta torica Ø60,83xØ50,17xØ5,33 |       | 1     |                        |  |  |  |  |  |  |       |        |
| 47   | Q307049 | Junta torica Ø95,75xØ85,09xØ5,33 |       | 1     |                        |  |  |  |  |  |  |       |        |
| 48   | Q307052 | Junta torica Ø60,83xØ50,17xØ5,33 |       | 1     |                        |  |  |  |  |  |  |       |        |
| 49   | Q232040 | Arandela plana A-6               |       | 4     |                        |  |  |  |  |  |  |       |        |
| 50   | Q262040 | Arandela muelle A-6              |       | 4     |                        |  |  |  |  |  |  |       |        |
| 51   | Q162040 | Tuerca exagonal M-6              |       | 4     |                        |  |  |  |  |  |  |       |        |
|      |         |                                  |       |       |                        |  |  |  |  |  |  |       |        |
|      |         |                                  |       |       |                        |  |  |  |  |  |  |       |        |
|      |         |                                  |       |       |                        |  |  |  |  |  |  |       |        |

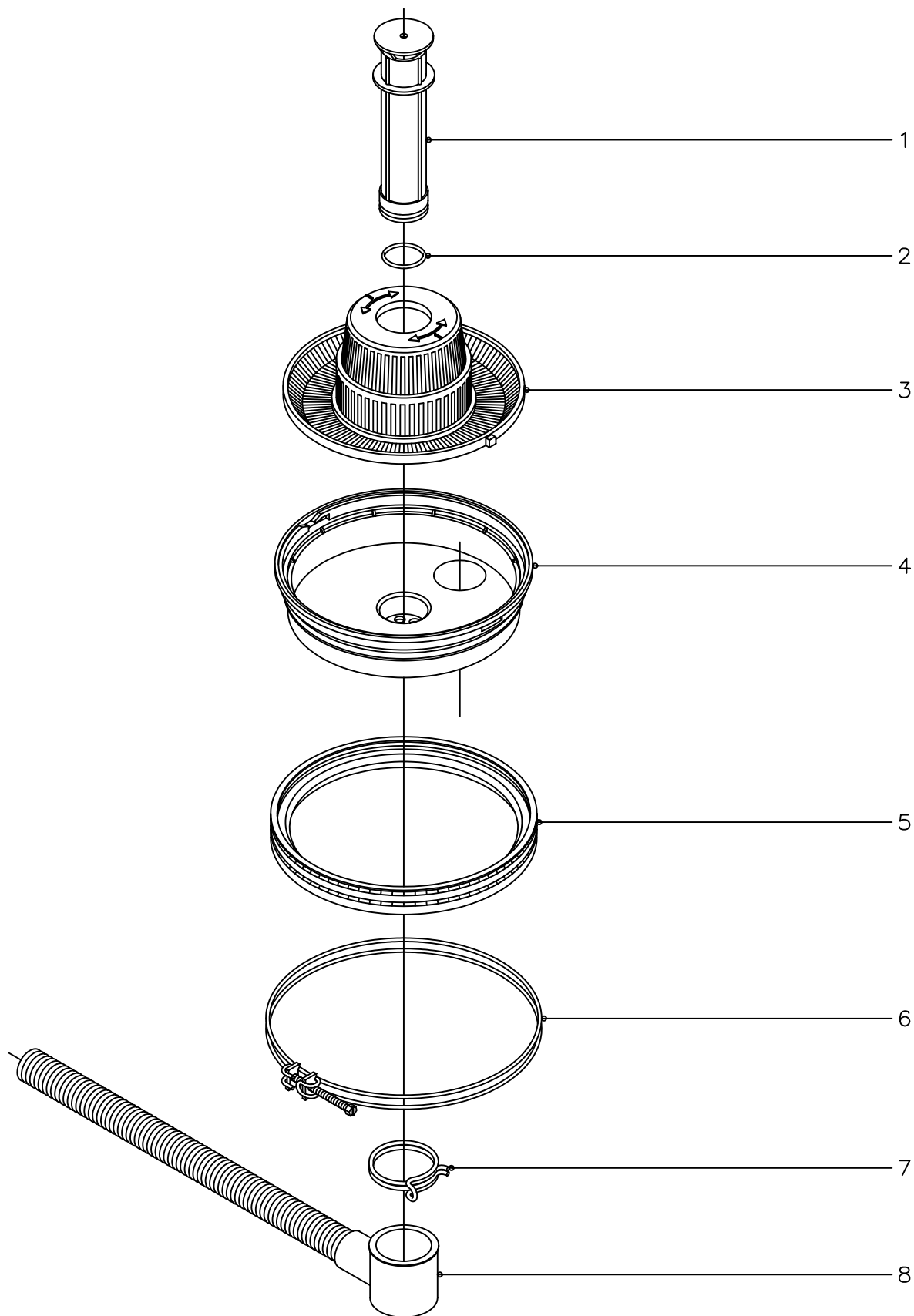

N plano  
C-1393

Firma  
*[Signature]*

Fecha  
6-2003

Aparato  
PARTE FUNCIONAL DESAGUE  
LAVAVAJILLAS FI-72

Lamina  
4

Fagor Industrial S.Coop. **FAGOR**   
Oriate

|             |                             |             |                                |              |               |
|-------------|-----------------------------|-------------|--------------------------------|--------------|---------------|
| <b>MOD.</b> | <b>LAVAVAJILLAS FRONTAL</b> | <b>ZONA</b> | <b>PARTE FUNCIONAL DESAGÜE</b> | <b>PLANO</b> | <b>C-1393</b> |
|-------------|-----------------------------|-------------|--------------------------------|--------------|---------------|

| <b>ITEM</b> | <b>CODIGO</b> | <b>DENOMINACION</b>              | <b>TEXTO</b> | <b>FI-72</b> |  |  |  |  |  |  |  |  |  | <b>NOTAS</b> |
|-------------|---------------|----------------------------------|--------------|--------------|--|--|--|--|--|--|--|--|--|--------------|
| 1           | Z200909       | Aliviadero                       |              | 1            |  |  |  |  |  |  |  |  |  |              |
| 2           | Q307051       | Junta torica Ø41,41xØ36,17xØ2,62 |              | 1            |  |  |  |  |  |  |  |  |  |              |
| 3           | Z200901       | Filtro aspiracion                |              | 1            |  |  |  |  |  |  |  |  |  |              |
| 4           | Z200906       | Cubeta                           |              | 1            |  |  |  |  |  |  |  |  |  |              |
| 5           | Z200907       | Junta cubeta                     |              | 1            |  |  |  |  |  |  |  |  |  |              |
| 6           | Z200908       | Abrazadera cubeta                |              | 1            |  |  |  |  |  |  |  |  |  |              |
| 7           | Q901308       | Abrazadera elastica 56 - 58,8    |              | 1            |  |  |  |  |  |  |  |  |  |              |
| 8           | Z200910       | Manguera de desagüe              |              | 1            |  |  |  |  |  |  |  |  |  |              |
|             |               |                                  |              |              |  |  |  |  |  |  |  |  |  |              |
|             |               |                                  |              |              |  |  |  |  |  |  |  |  |  |              |
|             |               |                                  |              |              |  |  |  |  |  |  |  |  |  |              |
|             |               |                                  |              |              |  |  |  |  |  |  |  |  |  |              |
|             |               |                                  |              |              |  |  |  |  |  |  |  |  |  |              |
|             |               |                                  |              |              |  |  |  |  |  |  |  |  |  |              |
|             |               |                                  |              |              |  |  |  |  |  |  |  |  |  |              |
|             |               |                                  |              |              |  |  |  |  |  |  |  |  |  |              |
|             |               |                                  |              |              |  |  |  |  |  |  |  |  |  |              |
|             |               |                                  |              |              |  |  |  |  |  |  |  |  |  |              |
|             |               |                                  |              |              |  |  |  |  |  |  |  |  |  |              |
|             |               |                                  |              |              |  |  |  |  |  |  |  |  |  |              |
|             |               |                                  |              |              |  |  |  |  |  |  |  |  |  |              |
|             |               |                                  |              |              |  |  |  |  |  |  |  |  |  |              |
|             |               |                                  |              |              |  |  |  |  |  |  |  |  |  |              |
|             |               |                                  |              |              |  |  |  |  |  |  |  |  |  |              |
|             |               |                                  |              |              |  |  |  |  |  |  |  |  |  |              |
|             |               |                                  |              |              |  |  |  |  |  |  |  |  |  |              |
|             |               |                                  |              |              |  |  |  |  |  |  |  |  |  |              |
|             |               |                                  |              |              |  |  |  |  |  |  |  |  |  |              |

| MOD. |         | LAVAVAJILLAS FRONTAL               |       | ZONA  | PARTE FUNCIONAL DE ACLARADO |  |  |  |  |  |  | PLANO | C-1394 |
|------|---------|------------------------------------|-------|-------|-----------------------------|--|--|--|--|--|--|-------|--------|
| ITEM | CODIGO  | DENOMINACION                       | TEXTO | FI-72 |                             |  |  |  |  |  |  |       | NOTAS  |
| 1    | 3676900 | Tubo goma negra Ø17xØ10x460        |       | 1     |                             |  |  |  |  |  |  |       |        |
| 2    | Q881302 | Abrazadera 12 - 20                 |       | 10    |                             |  |  |  |  |  |  |       |        |
| 3    | Z200707 | Soporte distribuidor superior      |       | 1     |                             |  |  |  |  |  |  |       |        |
| 4    | Z201106 | Racord en "Y"                      |       | 1     |                             |  |  |  |  |  |  |       |        |
| 5    | 3676900 | Tubo goma negra Ø17xØ10x780        |       | 1     |                             |  |  |  |  |  |  |       |        |
| 6    | 3676900 | Tubo goma negra Ø17xØ10x680        |       | 1     |                             |  |  |  |  |  |  |       |        |
| 7    | Z200703 | Pasamuros                          |       | 1     |                             |  |  |  |  |  |  |       |        |
| 8    | 3676900 | Tubo goma negra Ø17xØ10x200        |       | 2     |                             |  |  |  |  |  |  |       |        |
| 9    | 3704000 | Tubo goma negra Ø10,5xØ5x620       |       | 1     |                             |  |  |  |  |  |  |       |        |
| 10   | Q881308 | Abrazadera 8 - 14                  |       | 2     |                             |  |  |  |  |  |  |       |        |
| 11   | Z651123 | Dosificador tensoactivo            |       | 1     |                             |  |  |  |  |  |  |       |        |
| 12   | Z203007 | Casquillo                          |       | 2     |                             |  |  |  |  |  |  |       |        |
| 13   | Q041324 | Tornillo avellanado M-4x25         |       | 2     |                             |  |  |  |  |  |  |       |        |
| 14   | 3699200 | Conducto tensoactivo Ø6xØ4x650     |       | 1     |                             |  |  |  |  |  |  |       |        |
| 15   | N023064 | Pasamuros Ø6xØ13                   |       | 1     |                             |  |  |  |  |  |  |       |        |
| 16   | Z601153 | Filtro aspiracion tensoactivo      |       | 1     |                             |  |  |  |  |  |  |       |        |
| 17   | Z211101 | Deposito abrillantador tensoactivo |       | 1     |                             |  |  |  |  |  |  |       |        |
| 18   | Q012031 | Tornillo exagonal M-5x10           |       | 2     |                             |  |  |  |  |  |  |       |        |
| 19   | Q232030 | Arandela plana A-5                 |       | 2     |                             |  |  |  |  |  |  |       |        |
| 20   | Q307048 | Junta torica Ø16,18xØ9,12xØ3,53    |       | 1     |                             |  |  |  |  |  |  |       |        |
| 21   | Q012063 | Tornillo exagonal M-10x20          |       | 1     |                             |  |  |  |  |  |  |       |        |
| 22   | Z201710 | Cuerpo calderin                    |       | 1     |                             |  |  |  |  |  |  |       |        |
| 23   | Z601157 | Toma presion                       |       | 1     |                             |  |  |  |  |  |  |       |        |
| 24   | Z701135 | Electrovalvula entrada agua        |       | 1     |                             |  |  |  |  |  |  |       |        |
| 25   | Q152024 | Tornillo avellanado M-4x8          |       | 2     |                             |  |  |  |  |  |  |       |        |
| 26   | Z701132 | Filtro junta                       |       | 1     |                             |  |  |  |  |  |  |       |        |
| 27   | Q232030 | Arandela plana A-5                 |       | 2     |                             |  |  |  |  |  |  |       |        |
| 28   | Q012031 | Tornillo exagonal M-5x10           |       | 2     |                             |  |  |  |  |  |  |       |        |
| 29   | Z201101 | Escuadra amarre electrovalvula     |       | 1     |                             |  |  |  |  |  |  |       |        |

MOD.

LAVAVAJILLAS FRONTAL

ZONA



PARTE FUNCIONAL DE ACLARADO

PLANO

C-1394

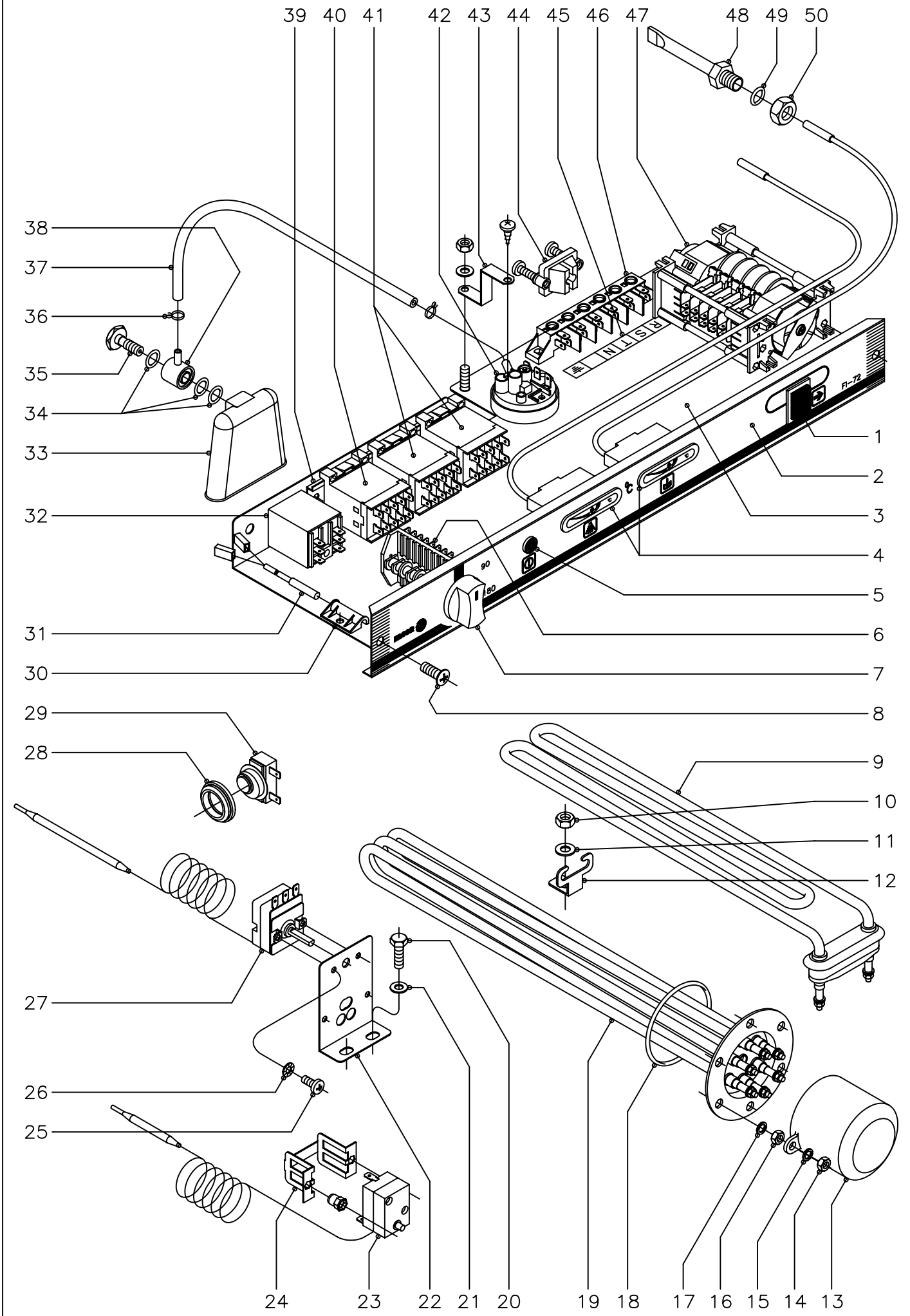
| ITEM | CODIGO  | DENOMINACION             | TEXTO | FI-72 |  |  |  |  |  |  |  |  | NOTAS |
|------|---------|--------------------------|-------|-------|--|--|--|--|--|--|--|--|-------|
| 30   | Z602121 | Manguera entrada de agua |       | 1     |  |  |  |  |  |  |  |  |       |
| 31   | Q307031 | Arandela junta           |       | 1     |  |  |  |  |  |  |  |  |       |
| 32   | R722631 | Fijacion conducciones    |       | 1     |  |  |  |  |  |  |  |  |       |
|      | Q162040 | Tuerca exagonal M-6      |       | 1     |  |  |  |  |  |  |  |  |       |
|      |         |                          |       |       |  |  |  |  |  |  |  |  |       |
|      |         |                          |       |       |  |  |  |  |  |  |  |  |       |
|      |         |                          |       |       |  |  |  |  |  |  |  |  |       |
|      |         |                          |       |       |  |  |  |  |  |  |  |  |       |
|      |         |                          |       |       |  |  |  |  |  |  |  |  |       |
|      |         |                          |       |       |  |  |  |  |  |  |  |  |       |
|      |         |                          |       |       |  |  |  |  |  |  |  |  |       |
|      |         |                          |       |       |  |  |  |  |  |  |  |  |       |
|      |         |                          |       |       |  |  |  |  |  |  |  |  |       |
|      |         |                          |       |       |  |  |  |  |  |  |  |  |       |
|      |         |                          |       |       |  |  |  |  |  |  |  |  |       |
|      |         |                          |       |       |  |  |  |  |  |  |  |  |       |
|      |         |                          |       |       |  |  |  |  |  |  |  |  |       |
|      |         |                          |       |       |  |  |  |  |  |  |  |  |       |
|      |         |                          |       |       |  |  |  |  |  |  |  |  |       |
|      |         |                          |       |       |  |  |  |  |  |  |  |  |       |
|      |         |                          |       |       |  |  |  |  |  |  |  |  |       |
|      |         |                          |       |       |  |  |  |  |  |  |  |  |       |
|      |         |                          |       |       |  |  |  |  |  |  |  |  |       |
|      |         |                          |       |       |  |  |  |  |  |  |  |  |       |



|                   |  |                 |  |             |  |
|-------------------|--|-----------------|--|-------------|--|
| N plano<br>C-1395 | Firma<br> | Fecha<br>6-2003 | Aparato<br>PARTE FUNCIONAL ELECTRICA<br>LAVAVAJILLAS FI-72 | Lamina<br>6 | Fagor Industrial S.Coop. <b>FAGOR</b> <br>Onate |
|-------------------|--|-----------------|--|-------------|--|

| MOD. |         | LAVAVAJILLAS FRONTAL              |       | ZONA  | PARTE FUNCIONAL ELECTRICA |  |  |  |  |  |  | PLANO | C-1395 |
|------|---------|-----------------------------------|-------|-------|---------------------------|--|--|--|--|--|--|-------|--------|
| ITEM | CODIGO  | DENOMINACION                      | TEXTO | FI-72 |                           |  |  |  |  |  |  |       | NOTAS  |
| 1    | Z213033 | Pulsador de marcha                |       | 1     |                           |  |  |  |  |  |  |       |        |
| 2    | Z262906 | Embellecedor adhesivo             |       | 1     |                           |  |  |  |  |  |  |       |        |
| 3    | Z212909 | Frente extraible                  |       | 1     |                           |  |  |  |  |  |  |       |        |
| 4    | Z263001 | Indicador analogico               |       | 2     |                           |  |  |  |  |  |  |       |        |
| 5    | R693056 | Piloto ambar                      |       | 1     |                           |  |  |  |  |  |  |       |        |
| 6    | Z213003 | Conmutador de funciones           |       | 1     |                           |  |  |  |  |  |  |       |        |
| 7    | R663062 | Boton de mando completo           |       | 1     |                           |  |  |  |  |  |  |       |        |
| 8    | Q152004 | Tornillo aplastado M-5x13         |       | 2     |                           |  |  |  |  |  |  |       |        |
| 9    | Z203601 | Resistencia tanque 2800 W. 230V.  |       | 1     |                           |  |  |  |  |  |  |       |        |
| 10   | Q162040 | Tuerca exagonal M-6               |       | 1     |                           |  |  |  |  |  |  |       |        |
| 11   | Q232040 | Arandela plana A-6                |       | 1     |                           |  |  |  |  |  |  |       |        |
| 12   | Z603602 | Soporte resistencia tanque        |       | 1     |                           |  |  |  |  |  |  |       |        |
| 13   | Z651731 | Caperuza resistencia calderin     |       | 1     |                           |  |  |  |  |  |  |       |        |
| 14   | Q163140 | Tuerca exagonal M-6               |       | 2     |                           |  |  |  |  |  |  |       |        |
| 15   | Q262040 | Arandela muelle A-6               |       | 2     |                           |  |  |  |  |  |  |       |        |
| 16   | Q163140 | Tuerca exagonal M-6               |       | 6     |                           |  |  |  |  |  |  |       |        |
| 17   | Q262040 | Arandela muelle A-6               |       | 6     |                           |  |  |  |  |  |  |       |        |
| 18   | Q307035 | Junta torica AN-36                |       | 1     |                           |  |  |  |  |  |  |       |        |
| 19   | Z241701 | Resistencia calderin 6000 W.230V. |       | 1     |                           |  |  |  |  |  |  |       |        |
| 20   | Q012031 | Tornillo exagonal M-5x10          |       | 2     |                           |  |  |  |  |  |  |       |        |
| 21   | Q232030 | Arandela plana A-5                |       | 2     |                           |  |  |  |  |  |  |       |        |
| 22   | Z203047 | Soporte termostatos               |       | 1     |                           |  |  |  |  |  |  |       |        |
| 23   | Z213014 | Termostato limitador Tecasa       |       | 1     |                           |  |  |  |  |  |  |       |        |
| 24   | Z203060 | Amarre limitador Tecasa           |       | 1     |                           |  |  |  |  |  |  |       |        |
|      | Q221341 | Remache exagonal M-4              |       | 2     |                           |  |  |  |  |  |  |       |        |
| 25   | Q153111 | Tornillo alomado M-4x8            |       | 4     |                           |  |  |  |  |  |  |       |        |
| 26   | Q242020 | Arandela abanico A-4              |       | 4     |                           |  |  |  |  |  |  |       |        |
| 27   | Z203014 | Termostato calderin               |       | 1     |                           |  |  |  |  |  |  |       |        |
| 28   | N503017 | Soporte termostato                |       | 1     |                           |  |  |  |  |  |  |       |        |



| MOD. |         | LAVAVAJILLAS FRONTAL                   |       | ZONA  | PARTE FUNCIONAL ELECTRICA |  |  |  |  |  |  | PLANO | C-1395 |
|------|---------|--|-------|-------|---------------------------|--|--|--|--|--|--|-------|--------|
| ITEM | CODIGO  | DENOMINACION                           | TEXTO | FI-72 |                           |  |  |  |  |  |  |       | NOTAS  |
| 29   | Z718405 | Termostato doble ( tanque )            |       | 1     |                           |  |  |  |  |  |  |       |        |
| 30   | Z203010 | Amarre interruptor magnetico           |       | 1     |                           |  |  |  |  |  |  |       |        |
| 31   | Z203009 | Interruptor magnetico                  |       | 1     |                           |  |  |  |  |  |  |       |        |
| 32   | Z203062 | Rele puerta 230 V., 50/60 Hz.          |       | 1     |                           |  |  |  |  |  |  |       |        |
| 33   | Z203011 | Camara presostato                      |       | 1     |                           |  |  |  |  |  |  |       |        |
| 34   | Q307003 | Junta torica Ø16,01xØ10,77xØ2,62       |       | 3     |                           |  |  |  |  |  |  |       |        |
| 35   | Z203013 | Tornillo presostato                    |       | 1     |                           |  |  |  |  |  |  |       |        |
| 36   | P102154 | Brida elastica para tubo               |       | 2     |                           |  |  |  |  |  |  |       |        |
| 37   | 3702400 | Tubo goma negra Ø8xØ4x1300             |       | 1     |                           |  |  |  |  |  |  |       |        |
| 38   | Z203012 | Empalme presostato                     |       | 1     |                           |  |  |  |  |  |  |       |        |
| 39   | Z103084 | Guia de contactores L=138              |       | 1     |                           |  |  |  |  |  |  |       |        |
| 40   | Z213007 | Contactador tanque 230 V., 50/60 Hz.   |       | 1     |                           |  |  |  |  |  |  |       |        |
| 41   | Z213007 | Contactador calderin 230 V., 50/60 Hz. |       | 2     |                           |  |  |  |  |  |  |       |        |
| 42   | Z203023 | Presostato de nivel                    |       | 1     |                           |  |  |  |  |  |  |       |        |
| 43   | Z602923 | Soporte presostato                     |       | 1     |                           |  |  |  |  |  |  |       |        |
| 44   | Z203020 | Retenedor de cable                     |       | 1     |                           |  |  |  |  |  |  |       |        |
| 45   | Z213005 | Rotulo adhesivo RSTN                   |       | 1     |                           |  |  |  |  |  |  |       |        |
| 46   | R253044 | Regleta de conexiones                  |       | 1     |                           |  |  |  |  |  |  |       |        |
| 47   | Z243004 | Programador ciclo                      |       | 1     |                           |  |  |  |  |  |  |       |        |
| 48   | Z263002 | Vaina para sonda ( Tanque )            |       | 1     |                           |  |  |  |  |  |  |       |        |
| 49   | Q306024 | Arandela junta Ø18xØ12,5x1,5           |       | 1     |                           |  |  |  |  |  |  |       |        |
| 50   | Q162070 | Tuerca exagonal M-12                   |       | 1     |                           |  |  |  |  |  |  |       |        |
|      |         |  |       |       |                           |  |  |  |  |  |  |       |        |
|      |         |  |       |       |                           |  |  |  |  |  |  |       |        |
|      |         |  |       |       |                           |  |  |  |  |  |  |       |        |
|      |         |  |       |       |                           |  |  |  |  |  |  |       |        |
|      |         |  |       |       |                           |  |  |  |  |  |  |       |        |
|      |         |  |       |       |                           |  |  |  |  |  |  |       |        |
|      |         |  |       |       |                           |  |  |  |  |  |  |       |        |

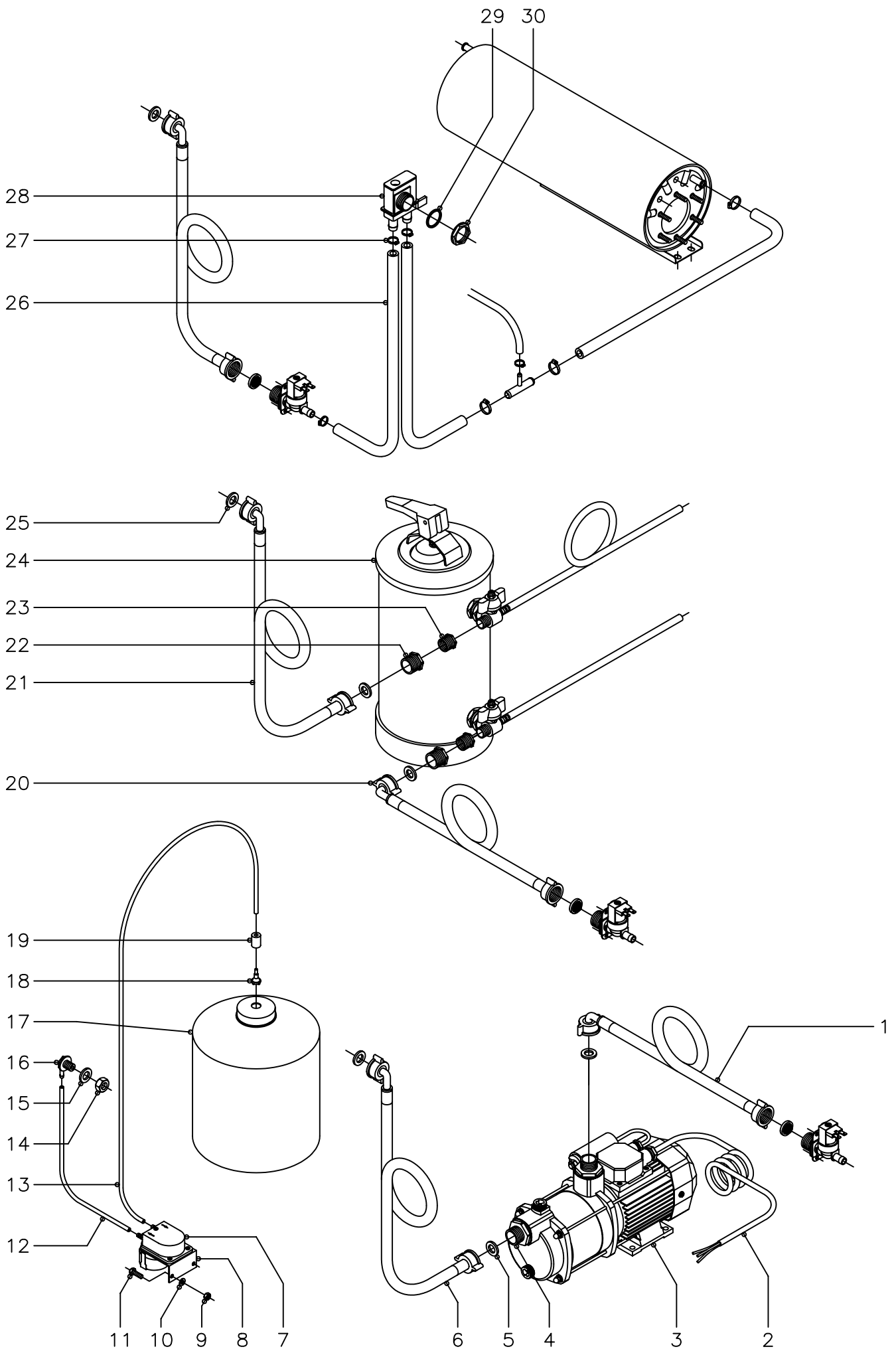

| MOD.   |         | LAVAVAJILLAS FRONTAL               |       | ZONA  | ACCESORIOS PARA LAVAVAJILLAS |  |  |  |  |  | PLANO | C-1396 |
|--|---------|------------------------------------|-------|-------|------------------------------|--|--|--|--|--|-------|--------|
| ITEM   | CODIGO  | DENOMINACION                       | TEXTO | FI-72 |                              |  |  |  |  |  |       | NOTAS  |
| <b>1210305187 KIT BOMBA PRESION</b>          |         |                                    |       |       |                              |  |  |  |  |  |       |        |
| 1  | -       | Manguera de maquina                |       | -     |                              |  |  |  |  |  |       |        |
| 2  | Z209510 | Cableado bomba de presion          |       | 1     |                              |  |  |  |  |  |       |        |
| 3  | Z209508 | Bomba de presion ( 230 V., 50 Hz.) |       | 1     |                              |  |  |  |  |  |       |        |
| 3  | Z209508 | Bomba de presion ( 230 V., 60 Hz.) |       | 1     |                              |  |  |  |  |  |       |        |
| 4  | Z209509 | Manguito                           |       | 2     |                              |  |  |  |  |  |       |        |
| 5  | Q307031 | Junta manguera entrada agua        |       | 2     |                              |  |  |  |  |  |       |        |
| 6  | Z602121 | Manguera entrada de agua           |       | 1     |                              |  |  |  |  |  |       |        |
| <b>1210305188 KIT DOSIFICADOR DETERGENTE</b> |         |                                    |       |       |                              |  |  |  |  |  |       |        |
| 7  | Z209521 | Dosificador de detergente          |       | 1     |                              |  |  |  |  |  |       |        |
|  | Q082005 | Tornillo chapa 4,2x13              |       | 2     |                              |  |  |  |  |  |       |        |
| 8  | Z209518 | Soporte dosificador de detergente  |       | 1     |                              |  |  |  |  |  |       |        |
| 9  | Q162030 | Tuerca exagonal M-5                |       | 2     |                              |  |  |  |  |  |       |        |
| 10   | Q232030 | Arandela plana A-5                 |       | 2     |                              |  |  |  |  |  |       |        |
| 11   | Q012031 | Tornillo exagonal M-5x10           |       | 2     |                              |  |  |  |  |  |       |        |
| 12   | 3699200 | Conducto detergente Ø6xØ4x500      |       | 1     |                              |  |  |  |  |  |       |        |
| 13   | 3699200 | Conducto detergente Ø6xØ4x2000     |       | 1     |                              |  |  |  |  |  |       |        |
| 14   | Q162070 | Tuerca exagonal M-12               |       | 1     |                              |  |  |  |  |  |       |        |
| 15   | Q307031 | Arandela junta Ø24xØ14x3           |       | 1     |                              |  |  |  |  |  |       |        |
| 16   | Z230902 | Pasamuros detergente               |       | 1     |                              |  |  |  |  |  |       |        |
| 17   | -       | Garrafa detergente                 |       | -     |                              |  |  |  |  |  |       |        |
| 18   | Z601153 | Filtro aspiracion                  |       | 1     |                              |  |  |  |  |  |       |        |
| 19   | Z701152 | Peso filtro                        |       | 1     |                              |  |  |  |  |  |       |        |
|  |         |                                    |       |       |                              |  |  |  |  |  |       |        |
|  |         |                                    |       |       |                              |  |  |  |  |  |       |        |
|  |         |                                    |       |       |                              |  |  |  |  |  |       |        |
|  |         |                                    |       |       |                              |  |  |  |  |  |       |        |

|      |                      |      |                              |       |        |
|------|----------------------|------|------------------------------|-------|--------|
| MOD. | LAVAVAJILLAS FRONTAL | ZONA | ACCESORIOS PARA LAVAVAJILLAS | PLANO | C-1396 |
|------|----------------------|------|------------------------------|-------|--------|

| ITEM | CODIGO  | DENOMINACION                               | TEXTO | FI-72 |  |  |  |  |  |  |  |  |  | NOTAS |
|------|---------|--|-------|-------|--|--|--|--|--|--|--|--|--|-------|
|      |         | <b>1210305191 KIT DESCALCIFICADOR 8l.</b>  |       |       |  |  |  |  |  |  |  |  |  |       |
| 20   | -       | Manguera de maquina                        |       | -     |  |  |  |  |  |  |  |  |  |       |
| 21   | Z602121 | Manguera entrada de agua                   |       | 1     |  |  |  |  |  |  |  |  |  |       |
| 22   | Z209515 | Tuerca reduccion 3/4" - 1/2"               |       | 2     |  |  |  |  |  |  |  |  |  |       |
| 23   | Z209516 | Tuerca reduccion 1/2" - 3/8"               |       | 2     |  |  |  |  |  |  |  |  |  |       |
| 24   | Z209511 | Descalcificador 8l.                        |       | 1     |  |  |  |  |  |  |  |  |  |       |
| 25   | Q307031 | Junta manguera entrada agua                |       | 2     |  |  |  |  |  |  |  |  |  |       |
|      |         |  |       |       |  |  |  |  |  |  |  |  |  |       |
|      |         | <b>1210305186 KIT DESCALCIFICADOR 12l.</b> |       |       |  |  |  |  |  |  |  |  |  |       |
| 20   | -       | Manguera de maquina                        |       | -     |  |  |  |  |  |  |  |  |  |       |
| 21   | Z602121 | Manguera entrada de agua                   |       | 1     |  |  |  |  |  |  |  |  |  |       |
| 22   | Z209515 | Tuerca reduccion 3/4" - 1/2"               |       | 2     |  |  |  |  |  |  |  |  |  |       |
| 23   | Z209516 | Tuerca reduccion 1/2" - 3/8"               |       | 2     |  |  |  |  |  |  |  |  |  |       |
| 24   | Z209507 | Descalcificador 12l.                       |       | 1     |  |  |  |  |  |  |  |  |  |       |
| 25   | Q307031 | Junta manguera entrada agua                |       | 2     |  |  |  |  |  |  |  |  |  |       |
|      |         |  |       |       |  |  |  |  |  |  |  |  |  |       |
|      |         | <b>1210305192 KIT DESCALCIFICADOR 16l.</b> |       |       |  |  |  |  |  |  |  |  |  |       |
| 20   | -       | Manguera de maquina                        |       | -     |  |  |  |  |  |  |  |  |  |       |
| 21   | Z602121 | Manguera entrada de agua                   |       | 1     |  |  |  |  |  |  |  |  |  |       |
| 22   | Z209515 | Tuerca reduccion 3/4" - 1/2"               |       | 2     |  |  |  |  |  |  |  |  |  |       |
| 23   | Z209516 | Tuerca reduccion 1/2" - 3/8"               |       | 2     |  |  |  |  |  |  |  |  |  |       |
| 24   | Z209512 | Descalcificador 16l.                       |       | 1     |  |  |  |  |  |  |  |  |  |       |
| 25   | Q307031 | Junta manguera entrada agua                |       | 2     |  |  |  |  |  |  |  |  |  |       |
|      |         |  |       |       |  |  |  |  |  |  |  |  |  |       |
|      |         |  |       |       |  |  |  |  |  |  |  |  |  |       |
|      |         |  |       |       |  |  |  |  |  |  |  |  |  |       |
|      |         |  |       |       |  |  |  |  |  |  |  |  |  |       |
|      |         |  |       |       |  |  |  |  |  |  |  |  |  |       |



| MOD. |         | LAVAVAJILLAS FRONTAL               | ZONA  | VARIOS |  |  |  |  |  | PLANO |  |                                      |
|------|---------|------------------------------------|-------|--------|--|--|--|--|--|-------|--|--------------------------------------|
| ITEM | CODIGO  | DENOMINACION                       | TEXTO | FI-72  |  |  |  |  |  |       |  | NOTAS                                |
|      | Z246131 | Folleto de instrucciones           |       | 1      |  |  |  |  |  |       |  |                                      |
|      | Z243009 | Esquema electrico adhesivo         |       | 1      |  |  |  |  |  |       |  | Plano HC-16501-1                     |
|      | Z243045 | Esquema electrico de montaje       |       | 1      |  |  |  |  |  |       |  | Plano HC-16217-9                     |
|      | Z203019 | Instalacion electrica              |       | 1      |  |  |  |  |  |       |  |                                      |
|      | Z213004 | Cableado auxiliar ( Portamandos )  |       | 1      |  |  |  |  |  |       |  |                                      |
|      | Z243002 | Cableado trifasico ( Calderin )    |       | 1      |  |  |  |  |  |       |  |                                      |
|      | 3713500 | Perfil cubrearistas plastico L=110 |       | 1      |  |  |  |  |  |       |  |                                      |
|      | 3713500 | Perfil cubrearistas plastico L=140 |       | 1      |  |  |  |  |  |       |  |                                      |
|      | Z200106 | Indicador dosificador              |       | 1      |  |  |  |  |  |       |  |                                      |
|      | Q012073 | Tornillo exagonal M-12x20          |       | 1      |  |  |  |  |  |       |  | Acceso a pasamuros detergente lavado |
|      | Q306024 | Arandela junta Ø18xØ12,5x1,5       |       | 1      |  |  |  |  |  |       |  | Acceso a pasamuros detergente lavado |
|      | Q162070 | Tuerca exagonal M-12               |       | 1      |  |  |  |  |  |       |  | Acceso a pasamuros detergente lavado |
|      |         |                                    |       |        |  |  |  |  |  |       |  |                                      |
|      |         |                                    |       |        |  |  |  |  |  |       |  |                                      |
|      |         |                                    |       |        |  |  |  |  |  |       |  |                                      |
|      |         |                                    |       |        |  |  |  |  |  |       |  |                                      |
|      |         |                                    |       |        |  |  |  |  |  |       |  |                                      |
|      |         |                                    |       |        |  |  |  |  |  |       |  |                                      |
|      |         |                                    |       |        |  |  |  |  |  |       |  |                                      |
|      |         |                                    |       |        |  |  |  |  |  |       |  |                                      |
|      |         |                                    |       |        |  |  |  |  |  |       |  |                                      |
|      |         |                                    |       |        |  |  |  |  |  |       |  |                                      |
|      |         |                                    |       |        |  |  |  |  |  |       |  |                                      |
|      |         |                                    |       |        |  |  |  |  |  |       |  |                                      |
|      |         |                                    |       |        |  |  |  |  |  |       |  |                                      |
|      |         |                                    |       |        |  |  |  |  |  |       |  |                                      |
|      |         |                                    |       |        |  |  |  |  |  |       |  |                                      |
|      |         |                                    |       |        |  |  |  |  |  |       |  |                                      |
|      |         |                                    |       |        |  |  |  |  |  |       |  |                                      |
|      |         |                                    |       |        |  |  |  |  |  |       |  |                                      |
|      |         |                                    |       |        |  |  |  |  |  |       |  |                                      |

| ITEM | CODIGO  | DENOMINACION                      | TEXTO | FI-72 |  |  |  |  |  |  |  |  | NOTAS |
|------|---------|-----------------------------------|-------|-------|--|--|--|--|--|--|--|--|-------|
| 5    | Z203511 | Bomba de lavado ( 230 V., 60Hz. ) |       | 1     |  |  |  |  |  |  |  |  |       |
|      |         |                                   |       |       |  |  |  |  |  |  |  |  |       |
|      |         |                                   |       |       |  |  |  |  |  |  |  |  |       |
|      |         |                                   |       |       |  |  |  |  |  |  |  |  |       |
|      |         |                                   |       |       |  |  |  |  |  |  |  |  |       |
|      |         |                                   |       |       |  |  |  |  |  |  |  |  |       |
|      |         |                                   |       |       |  |  |  |  |  |  |  |  |       |
|      |         |                                   |       |       |  |  |  |  |  |  |  |  |       |
|      |         |                                   |       |       |  |  |  |  |  |  |  |  |       |
|      |         |                                   |       |       |  |  |  |  |  |  |  |  |       |
|      |         |                                   |       |       |  |  |  |  |  |  |  |  |       |
|      |         |                                   |       |       |  |  |  |  |  |  |  |  |       |
|      |         |                                   |       |       |  |  |  |  |  |  |  |  |       |
|      |         |                                   |       |       |  |  |  |  |  |  |  |  |       |
|      |         |                                   |       |       |  |  |  |  |  |  |  |  |       |
|      |         |                                   |       |       |  |  |  |  |  |  |  |  |       |
|      |         |                                   |       |       |  |  |  |  |  |  |  |  |       |
|      |         |                                   |       |       |  |  |  |  |  |  |  |  |       |
|      |         |                                   |       |       |  |  |  |  |  |  |  |  |       |
|      |         |                                   |       |       |  |  |  |  |  |  |  |  |       |
|      |         |                                   |       |       |  |  |  |  |  |  |  |  |       |
|      |         |                                   |       |       |  |  |  |  |  |  |  |  |       |

|      |                                   |      |                                     |  |  |  |  |  |  |  |       |  |
|------|-----------------------------------|------|-------------------------------------|--|--|--|--|--|--|--|-------|--|
| MOD. | <b>LAVAVAJILLAS FRONTAL ASPES</b> | ZONA | <b>PIEZAS ESPECIFICAS ( ASPES )</b> |  |  |  |  |  |  |  | PLANO |  |
|------|-----------------------------------|------|-------------------------------------|--|--|--|--|--|--|--|-------|--|

| ITEM | CODIGO  | DENOMINACION            | TEXTO | FI-72 |  |  |  |  |  |  |  |  |  |  | NOTAS |
|------|---------|-------------------------|-------|-------|--|--|--|--|--|--|--|--|--|--|-------|
|      | Z268701 | Embellecedor adhesivo   |       | 1     |  |  |  |  |  |  |  |  |  |  |       |
|      | Z208702 | Asa puerta              |       | 1     |  |  |  |  |  |  |  |  |  |  |       |
|      | Z448702 | Boton de mando completo |       | 1     |  |  |  |  |  |  |  |  |  |  |       |
|      |         |                         |       |       |  |  |  |  |  |  |  |  |  |  |       |
|      |         |                         |       |       |  |  |  |  |  |  |  |  |  |  |       |
|      |         |                         |       |       |  |  |  |  |  |  |  |  |  |  |       |
|      |         |                         |       |       |  |  |  |  |  |  |  |  |  |  |       |
|      |         |                         |       |       |  |  |  |  |  |  |  |  |  |  |       |
|      |         |                         |       |       |  |  |  |  |  |  |  |  |  |  |       |
|      |         |                         |       |       |  |  |  |  |  |  |  |  |  |  |       |
|      |         |                         |       |       |  |  |  |  |  |  |  |  |  |  |       |
|      |         |                         |       |       |  |  |  |  |  |  |  |  |  |  |       |
|      |         |                         |       |       |  |  |  |  |  |  |  |  |  |  |       |
|      |         |                         |       |       |  |  |  |  |  |  |  |  |  |  |       |
|      |         |                         |       |       |  |  |  |  |  |  |  |  |  |  |       |
|      |         |                         |       |       |  |  |  |  |  |  |  |  |  |  |       |
|      |         |                         |       |       |  |  |  |  |  |  |  |  |  |  |       |
|      |         |                         |       |       |  |  |  |  |  |  |  |  |  |  |       |
|      |         |                         |       |       |  |  |  |  |  |  |  |  |  |  |       |
|      |         |                         |       |       |  |  |  |  |  |  |  |  |  |  |       |
|      |         |                         |       |       |  |  |  |  |  |  |  |  |  |  |       |
|      |         |                         |       |       |  |  |  |  |  |  |  |  |  |  |       |
|      |         |                         |       |       |  |  |  |  |  |  |  |  |  |  |       |
|      |         |                         |       |       |  |  |  |  |  |  |  |  |  |  |       |
|      |         |                         |       |       |  |  |  |  |  |  |  |  |  |  |       |
|      |         |                         |       |       |  |  |  |  |  |  |  |  |  |  |       |
|      |         |                         |       |       |  |  |  |  |  |  |  |  |  |  |       |
|      |         |                         |       |       |  |  |  |  |  |  |  |  |  |  |       |
|      |         |                         |       |       |  |  |  |  |  |  |  |  |  |  |       |



| MOD. LAVAVAJILLAS FRONTAL |         | ZONA                              |       | PIEZAS ESPECIFICAS ( FI-72 T ) |  |  |  |  |  |  |  |  | PLANO |       |
|---------------------------|---------|-----------------------------------|-------|--------------------------------|--|--|--|--|--|--|--|--|-------|-------|
| ITEM                      | CODIGO  | DENOMINACION                      | TEXTO | FI-72 T                        |  |  |  |  |  |  |  |  |       | NOTAS |
|                           | Z268301 | Embellecedor adhesivo             |       | 1                              |  |  |  |  |  |  |  |  |       |       |
|                           | Z268313 | Panel frontal                     |       | 1                              |  |  |  |  |  |  |  |  |       |       |
|                           | Z203511 | Bomba de lavado ( 230 V., 60Hz.)  |       | 1                              |  |  |  |  |  |  |  |  |       |       |
|                           | Z208321 | Bomba de presion ( 230 V., 60Hz.) |       | 1                              |  |  |  |  |  |  |  |  |       |       |
|                           | Q012043 | Tornillo exagonal M-6x20          |       | 4                              |  |  |  |  |  |  |  |  |       |       |
|                           | Q232040 | Arandela plana A-6                |       | 4                              |  |  |  |  |  |  |  |  |       |       |
|                           | Q306037 | Arandela plana Ø42,5xØ32x1,5      |       | 4                              |  |  |  |  |  |  |  |  |       |       |
|                           | Q222012 | Tuerca exagonal autoblocante M-6  |       | 4                              |  |  |  |  |  |  |  |  |       |       |
|                           | Z209509 | Manguito                          |       | 2                              |  |  |  |  |  |  |  |  |       |       |
|                           | Z278322 | Manguera entrada de agua L=700    |       | 1                              |  |  |  |  |  |  |  |  |       |       |
|                           | Z278323 | Cableado bomba de presion         |       | 1                              |  |  |  |  |  |  |  |  |       |       |
|                           | Z268302 | Programador (230 V., 60 Hz.)      |       | 1                              |  |  |  |  |  |  |  |  |       |       |
|                           | Z208311 | Folleto de instrucciones          |       | 1                              |  |  |  |  |  |  |  |  |       |       |
|                           |         |                                   |       |                                |  |  |  |  |  |  |  |  |       |       |
|                           |         |                                   |       |                                |  |  |  |  |  |  |  |  |       |       |
|                           |         |                                   |       |                                |  |  |  |  |  |  |  |  |       |       |
|                           |         |                                   |       |                                |  |  |  |  |  |  |  |  |       |       |
|                           |         |                                   |       |                                |  |  |  |  |  |  |  |  |       |       |
|                           |         |                                   |       |                                |  |  |  |  |  |  |  |  |       |       |
|                           |         |                                   |       |                                |  |  |  |  |  |  |  |  |       |       |
|                           |         |                                   |       |                                |  |  |  |  |  |  |  |  |       |       |
|                           |         |                                   |       |                                |  |  |  |  |  |  |  |  |       |       |
|                           |         |                                   |       |                                |  |  |  |  |  |  |  |  |       |       |
|                           |         |                                   |       |                                |  |  |  |  |  |  |  |  |       |       |
|                           |         |                                   |       |                                |  |  |  |  |  |  |  |  |       |       |
|                           |         |                                   |       |                                |  |  |  |  |  |  |  |  |       |       |
|                           |         |                                   |       |                                |  |  |  |  |  |  |  |  |       |       |
|                           |         |                                   |       |                                |  |  |  |  |  |  |  |  |       |       |

3N ~ 380/415V.

3 ~ 220V.

1N ~ 220 V./ 1N ~ 240V.

Mod.: FI - 64

FI - 72

KM - 64

FI - 72 T

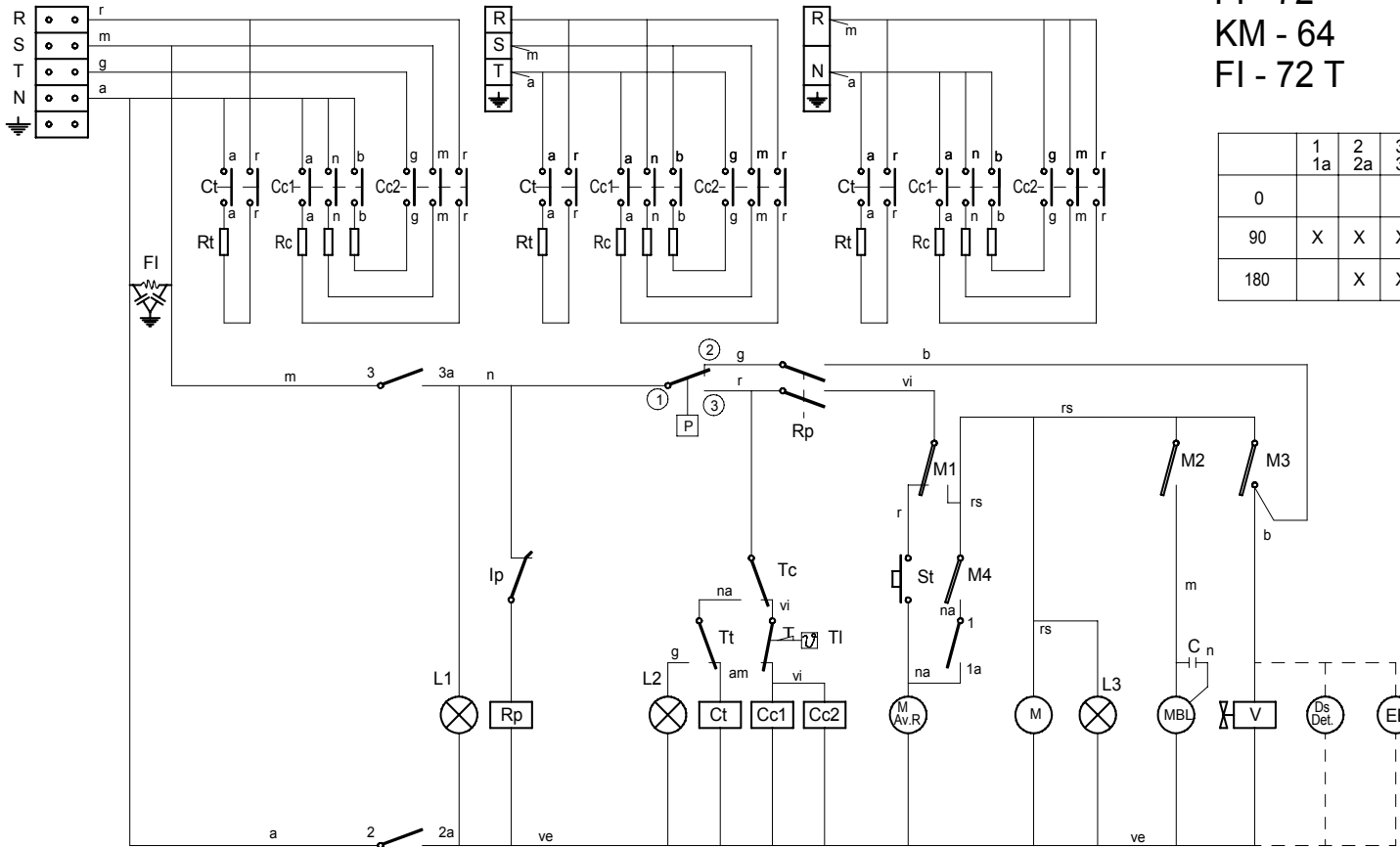

|     |    |    |    |
|-----|----|----|----|
|     | 1  | 2  | 3  |
|     | 1a | 2a | 3a |
| 0   |    |    |    |
| 90  | X  | X  | X  |
| 180 |    | X  | X  |

①

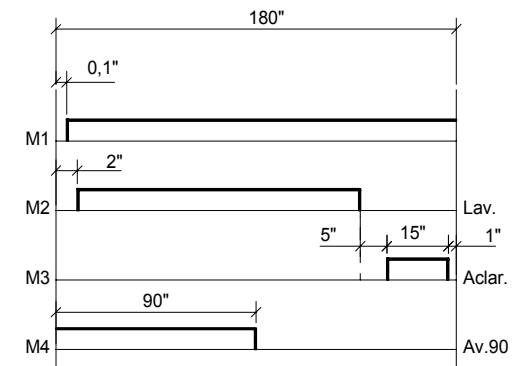

**CODIGO DE COLORES:**

- r = rojo-red-rouge
- m = marron-brown-marron
- g = gris-grey-gris
- n = negro-black-noir
- a = azul-blue-bleu
- b = blanco-white-blanc
- vi = violeta-violette-violet
- am = amarillo-yellow-jaune
- na = naranja-orange-orange
- rs = rosa-rose-pink
- ve = verde-green-vert
- am/ve = amarillo verde-yellow green-jaune vert

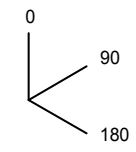

**NOTAS.-**

- Fondo del esquema: Color Blanco
- Grabaciones: Color Negro
- Dimensiones: 235x120
- N° Clasificación: Parte inferior dcha.

- I<sub>G</sub> = Interruptor General
- L1 = Lámpara de marcha
- Ip = Micro de puerta
- Rp = Relé puerta
- P = Presostato
- Tc = Termostato calderin
- Tt = Termostato tanque
- TI = Termostato limitador de calderin
- Cc1, Cc2 = Contactor calderin
- Ct = Contactor tanque
- L2 = Lámpara máquina preparada
- Rc = Resistencia calderin
- St = Pulsador de marcha
- FI = Filtro de interferencias

- Rt = Resistencia tanque
- M.Av.R = Motor programador Avance Rápido
- M = Motor programador
- M1 = Micro programador marcha
- M2 = Micro programador lavado
- M3 = Micro programador aclarado
- M4 = Micro programador Avance 90"
- L3 = Lámpara de ciclo
- MBL = Motobomba lavado
- C = Condensador de motobomba
- V = Válvula de llenado y aclarado
- Ds Det = Dosificador de detergente (opcional)
- EB = Electrobomba de presión (opcional)

|                          |                                 |                |                                      |                       |
|--------------------------|---------------------------------|----------------|--------------------------------------|-----------------------|
| Esquema teórico adhesivo |                                 | Papel adhesivo | Z-243009                             |                       |
| Nº                       | Pieza                           | Cant.          | Material                             | Nº Clasificación      |
| Nº                       | Modificación                    | Propuesta de   |                                      | Fecha                 |
| ①                        | Introducir denominación FI-72 T | Palacio        |                                      | 21-4-98               |
|                          |                                 |                |                                      | Tolerancias generales |
|                          |                                 |                |                                      | <5±                   |
|                          |                                 |                |                                      | 5-25±                 |
|                          |                                 |                |                                      | 25-50±                |
|                          |                                 |                |                                      | 50-100±               |
|                          |                                 |                |                                      | > 100±                |
|                          |                                 |                |                                      | ∞±                    |
| Dibujado                 | Firma                           | Fecha          | Mecanizado superficial               |                       |
| Proyectado               | S. N.                           | 28-9-95        | FAGOR                                |                       |
| Comprobado               |                                 |                | Fagor Industrial, Koop, Elk, Mugatua |                       |
| Escala                   |                                 |                | LAVAVAJILLAS                         |                       |
|                          |                                 |                |                                      | Plano numero          |
|                          |                                 |                |                                      | HC-16501 -1           |
|                          |                                 |                |                                      | Sustituye al Nº       |
|                          |                                 |                |                                      | Sustituido por        |

Plano hau ez dateke erabili ez berritza gure baimenitz gabe

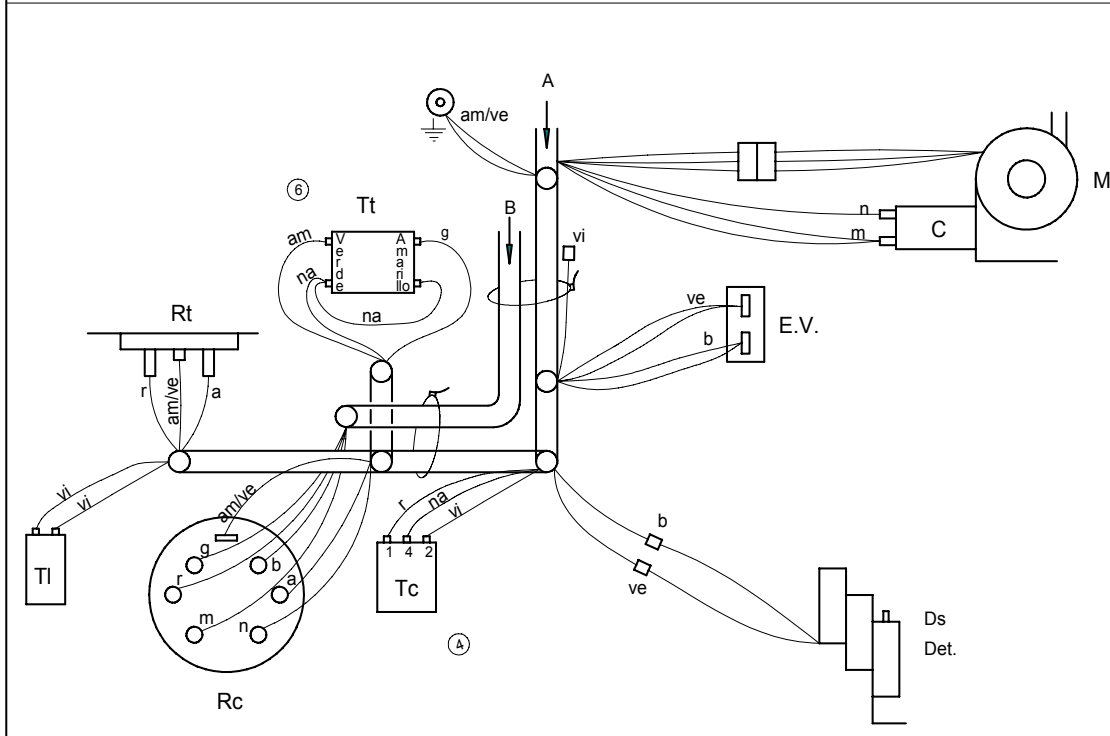
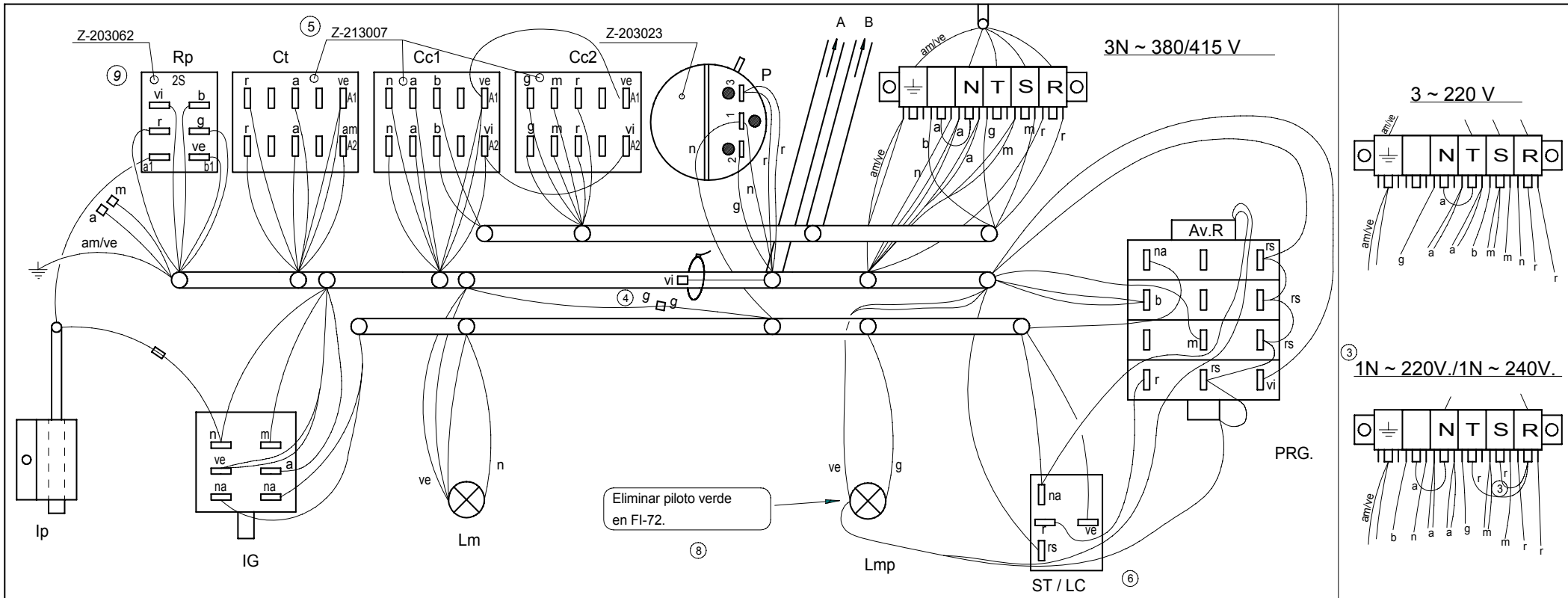

|   |  |                                      |               |                        |            |
|---|--|--------------------------------------|---------------|------------------------|------------|
| Esquema de montaje FI-64; FI-72                             |  | Z-243045                             |               |                        |            |
| Nº  | Pieza  | Nº                                   | Clasificación | Acabado                |            |
| Nº  | Modificación   | Propuesta de                         | Fecha         | Tolerancias generales  |            |
| ④   | Cambiar de color Marrón a Gris                         | Maillo                               | 28-9-95       | <5±                    | 50- 100± : |
| ⑤   | Sustituir 1 rele Z-203018 por Z-213007                 | Albes                                | 30-11-95      | 5-25± :                | > 100±     |
| ⑥   | Sustituir Termostato tanque y ST/LC                    | Maillo                               | 19-5-97       | 25- 50± :              | ∞±         |
| ⑦   | Introducir N° Clasificación                            | Palacio                              | 10-7-97       |                        |            |
| ⑧   | Introducir Nota eliminación piloto verde               | Palacio                              | 02-01-01      |                        |            |
| ⑨   | Sustituir Z-203018 por Z-203062, cambiar colores en Rp | J.M.P.A.                             | 02-05-13      |                        |            |
| Dibujado  |  | Firma                                | Fecha         | Mecanizado superficial |            |
| Proyectado  |  | S. N.                                | 6-7-93        | FAGOR                  |            |
| Comprobado  |  | Fagor Industrial, Koop, Elk, Mugatua |               | Plano numero           |            |
| Escala  |  | LAVAVAJILLAS                         |               | HC-16217-9             |            |
| Plano hau ez daiteke erabili ez bezitza gure baimenitz gabe |  |                                      |               | Sustituye al N°        |            |
|   |  |                                      |               | Sustituido por         |            |