

DESPIECE TÉCNICO TECHNICAL PARTS

Lavavajillas
Dishwasher

MODELOS
CO-502 DD / B DD

Enero 2015 January
Revisado Enero 2015 January Revised



C-33342

N.º plano / Drawing N.º

Iban R.

Firma / Signature

2014-12

Fecha / Date

LAVAVAJILLAS CO-502 DISHWASHER

Aparato / Appliance

ARMAZON / FRAME

1

Lamina / Sheet

Opote

Fagor Industrial S. Coop. FAGOR

ITEM MARCADO EN COLOR = REPUESTO RECOMENDADO
COLOURED ITEM = RECOMMENDED SPARE PART

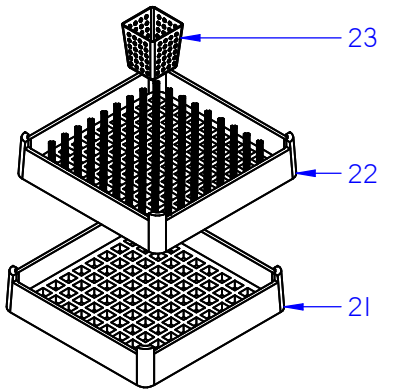
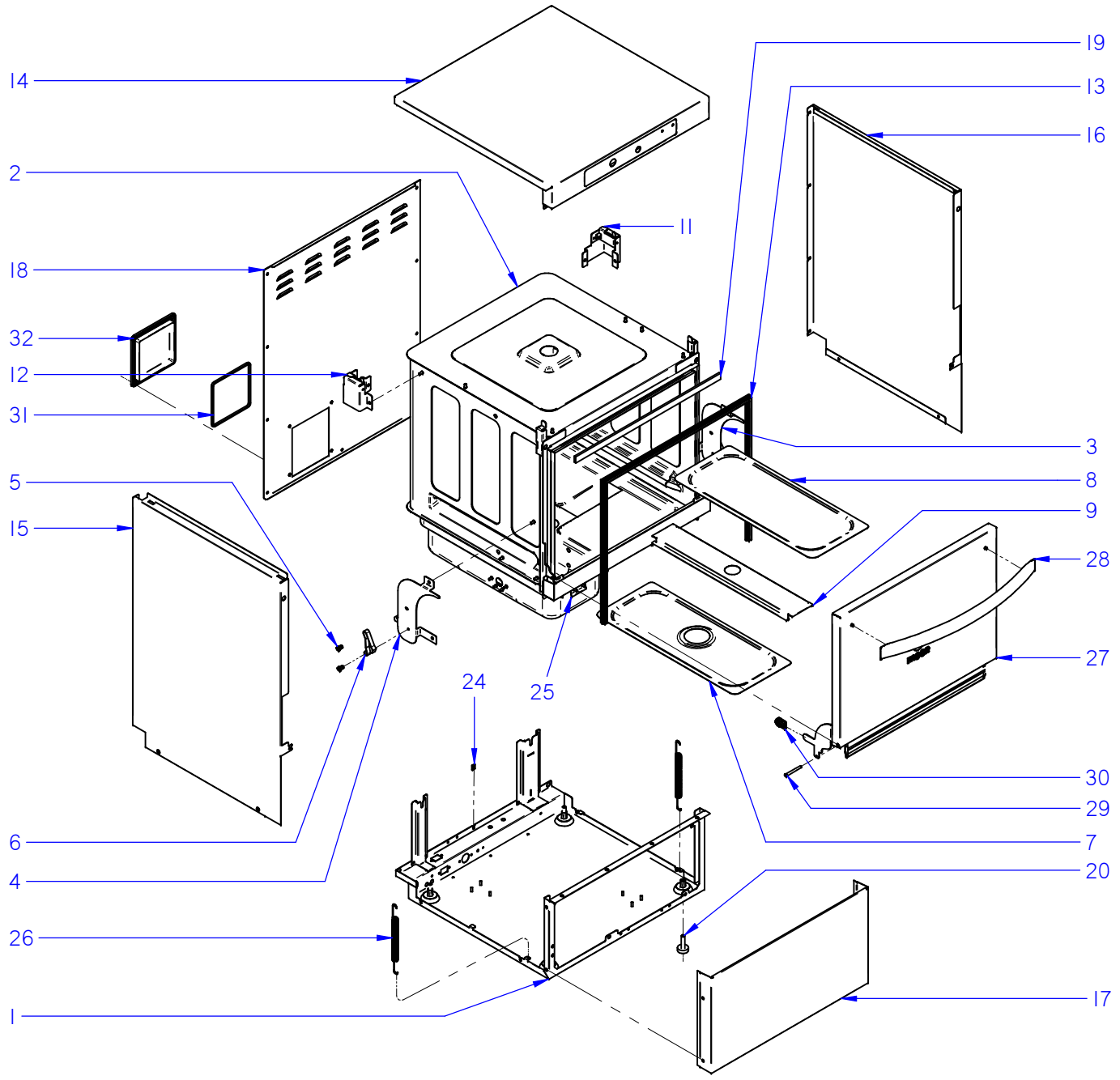

ZONA / ZONE	ARMAZON / FRAME	LÁMINA / DRAWING	C-3342	FAGOR 
--------------------	------------------------	-------------------------	---------------	--

ITEM	REFERENCIA REFERENCE	DENOMINACIÓN	DENOMINATION	CO-502								RECOMMENDED	ELIMINADO ELIMINATED	INTRODUCIDO INTRODUCED	NOTAS / NOTES
1	12097740	CONJUNTO_BASE_ARMAZON_AF	BASE FRAME COMPLETE	1											
2	12049291	CAJA SOLDADA CONCEPT	WELDED TUB CONCEPT	1											
3	12043455	SOPORTE RESORTE PUERTA DCHA	DOOR SPRING RIGHT SUPPORT	1											
4	12043457	SOPORTE RESORTE PUERTA IZDA	DOOR SPRING LEFT SUPPORT	1											
5	12043554	EJE RESORTE	SPRING SHAFT	4											
6	12043429	RESORTE PUERTA	DOOR SPRING	2											
7	12109967	BANDEJA FILTRO ALIVIADERO	SPILLWAY FILTER TRAY	1											
8	12109964	BANDEJA CONCEPT LISA (DCHA.)	CONCEPT FLAT TRAY (RIGHT)	1											
9	12098244	SOPORTE CENTRAL BANDEJAS	CENTRAL TRAYS SUPPORT	1											
11	12103774	SUJECCIÓN PANEL LATERAL DCHO.	RIGHT SIDE PANEL FASTENING	1											
12	12103787	SUJECCIÓN PANEL LATERAL IZDO.	LEFT SIDE PANEL FASTENING	1											
13	12049352	BURLETE APERTURA FRONTAL	FRONT LOADING GASKET	1											
14	12113950	TAPA PORTAMANDOS W	CONTROL PANEL COVER W	1											
15	12122224	PANEL LATERAL IZDO	LEFT SIDE PANEL	1											
16	12122222	PANEL LATERAL DCHO	RIGHT SIDE PANEL	1											
17	12122220	PANEL FRONTAL	FRONT PANEL	1											
18	12120613	PANEL POSTERIOR ADVANCE	REAR PANEL ADVANCE	1											
19	12111378	ESPUMA CIERRE TAPA PORTAMAND.	CTRL. P. COVER CLOSURE FOAM	1											
20	12024163	PATA REGULABLE	REGULABLE FEET	4											
21	12025011	CESTILLO BASE CT-10	CT-10 BASE BASKET	1											
22	12024990	CESTILLO PLATOS CP-16-18	CP-16-18 PLATES BASKET	1											
23	12023745	CESTILLO CUBIERTOS	CUTLERY BASKET	1											
24	12087215	TUERCA RÁPIDA M5 MIKALOR	MIKALOR QUICK NUT M5	19											
25	12044905	SOPORTE BULBO TERMOMETRO	THERMOSTAT BULB SUPPORT	1											
26	12097279	MUELLE APERTURA FRONTAL	FRONT LOADING SPRING	2											
27	12097227	PUERTA COMPLETA	COMPLETE DOOR	1											
28	12049466	ASA PUERTA	DOOR HANDLE	1											
29	12048418	TORN_ESPECIAL_EJE_PUERTA_M6	DOOR AXIS SPECIAL SCREW M-6	2											
30	12047927	TOPE BISAGRA	HINGE DOORSTOP	2											
31	12096947	JUNTA TAPA	COVER'S SEAL	1											
32	12095220	TAPA PLASTICO CAJA CONEXIONES	CONNECTIONS BOX COVER	1											

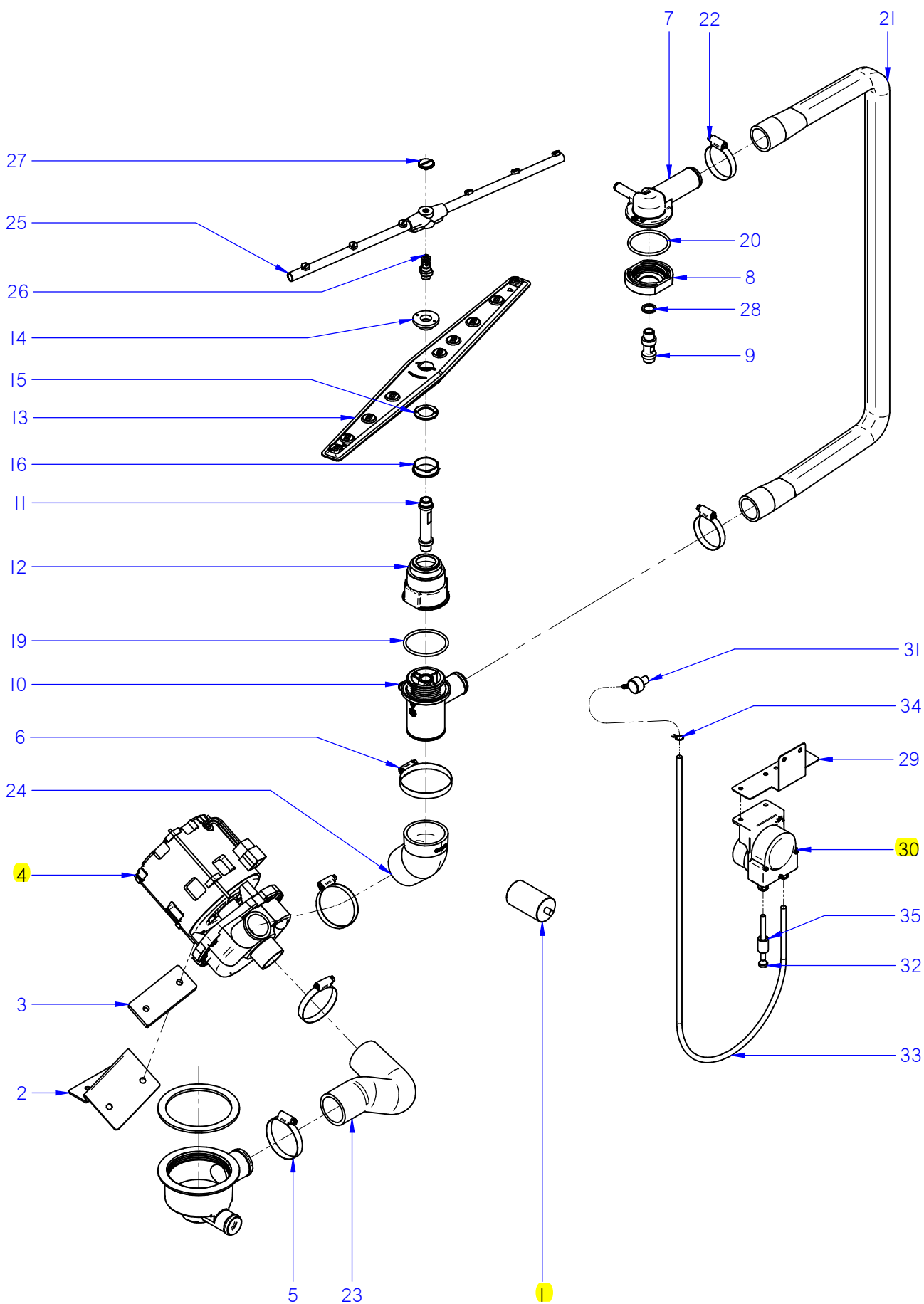

ITEM MARCADO EN COLOR = REPUESTO RECOMENDADO
 COLOURED ITEM = RECOMMENDED SPARE PART

N plano / Drawing N.	Firma / Signature	Fecha / Date	Aparato / Appliance	PARTE FUNCIONAL LAVADO / WASHING FUNCTIONAL PART	Lamina / Sheet	Fagor Industrial S.Coop. FAGOR
C-3343	Iban R	12-2014	LAVAVAJILLAS CO-502 / DD	DISHWASHER	2	Oñate

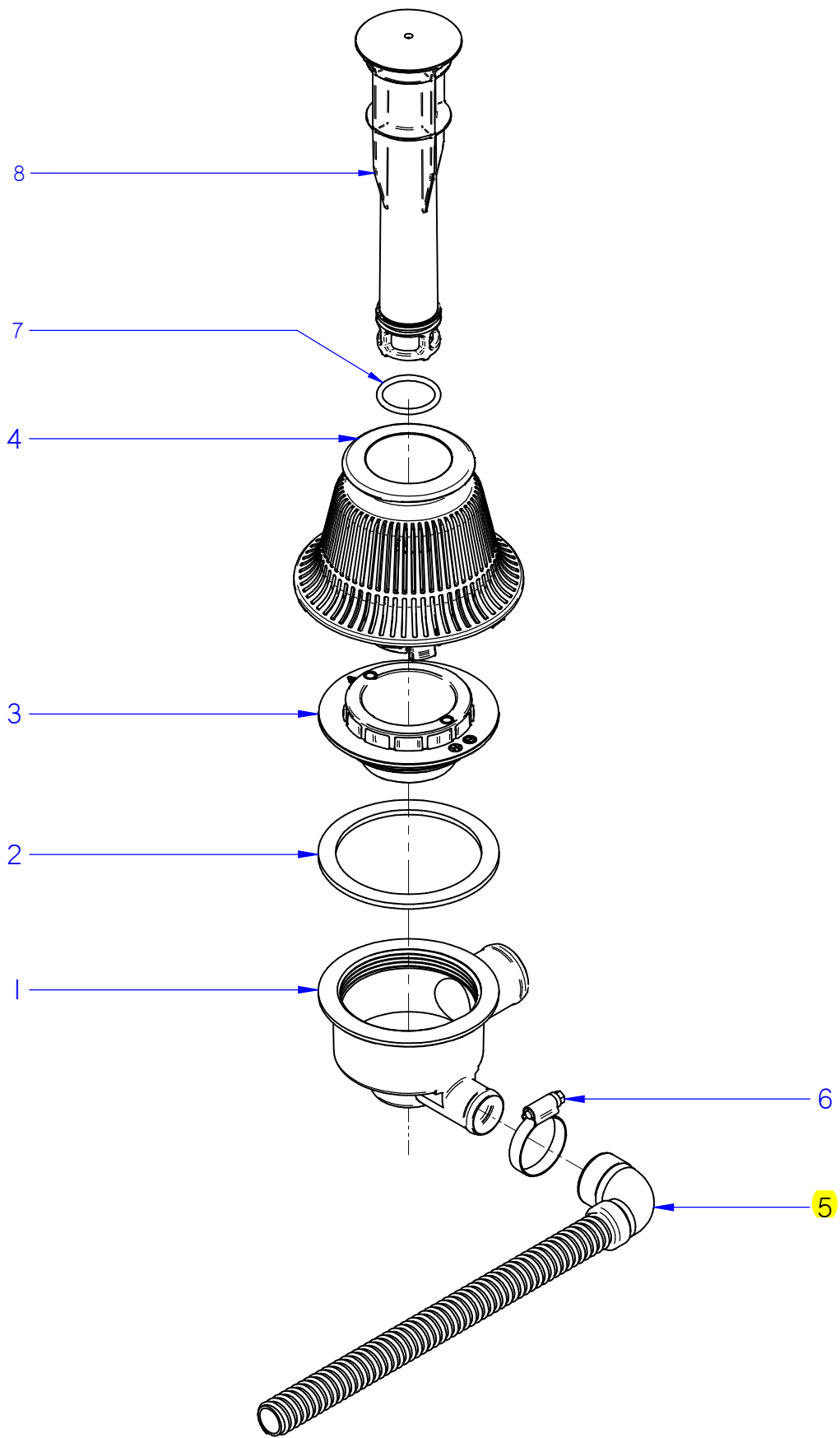

ITEM MARCADO EN COLOR = REPUESTO RECOMENDADO
 COLOURED ITEM = RECOMMENDED SPARE PART

N plano / Drawing N.	Firma / Signature	Fecha / Date	Aparato / Appliance	DESAGÜE / DRAINING PART	Lamina / Sheet	Fagor Industrial S.Coop. FAGOR
C-3344	Iban R	12-2014	LAVAVAJILLAS CO-502 DISHWASHER		3	Oñate

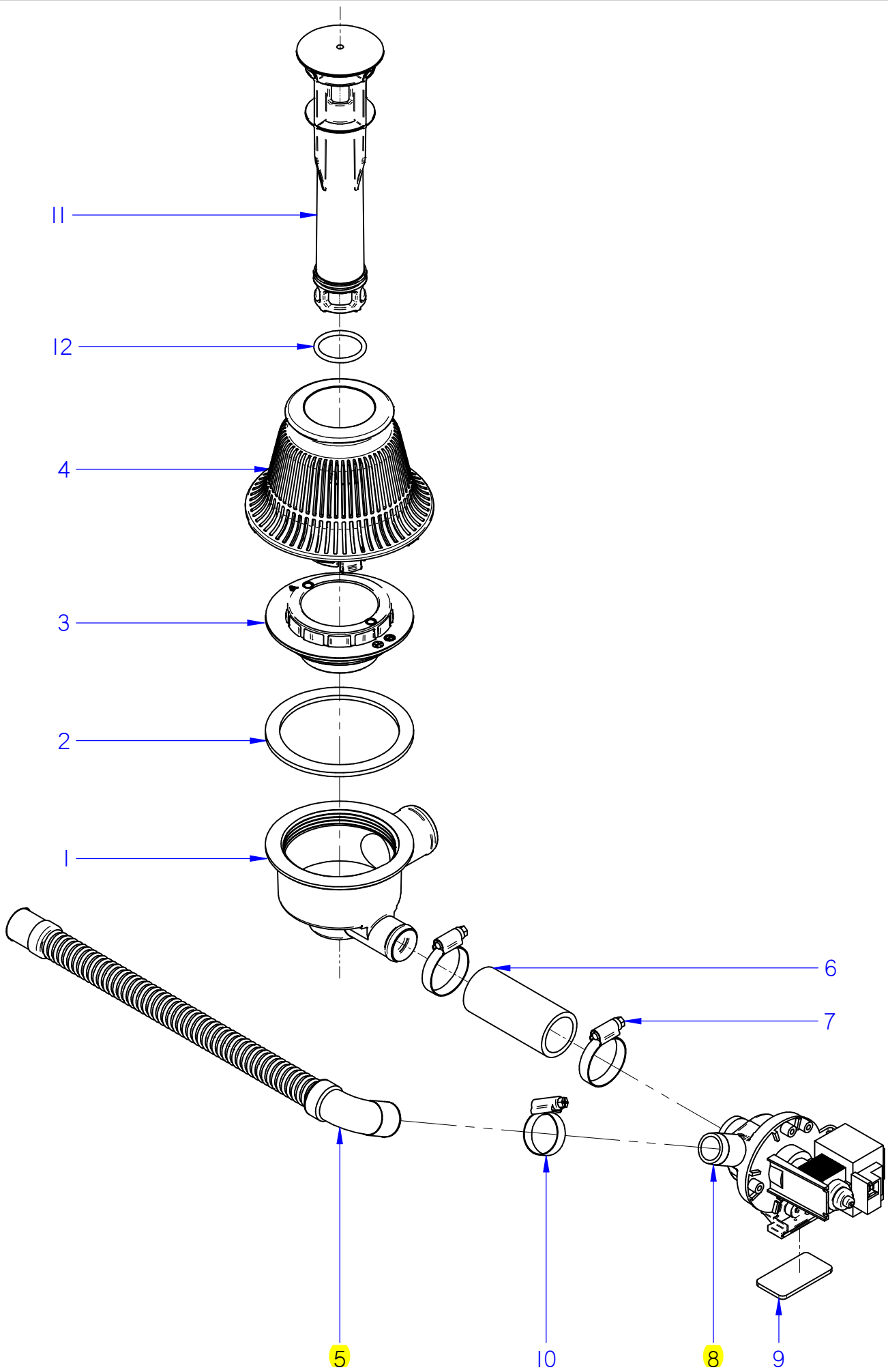

ITEM MARCADO EN COLOR = REPUESTO RECOMENDADO
 COLOURED ITEM = RECOMMENDED SPARE PART

N plano / Drawing N.	Firma / Signature	Fecha / Date	Aparato / Appliance	DESAGÜE / DRAINING PART	Lamina / Sheet	Fagor Industrial S.Coop. FAGOR
C-3345	Iban R	12-2014	LAVAVAJILLAS COP-502 B DISHWASHER		4	 Oñate

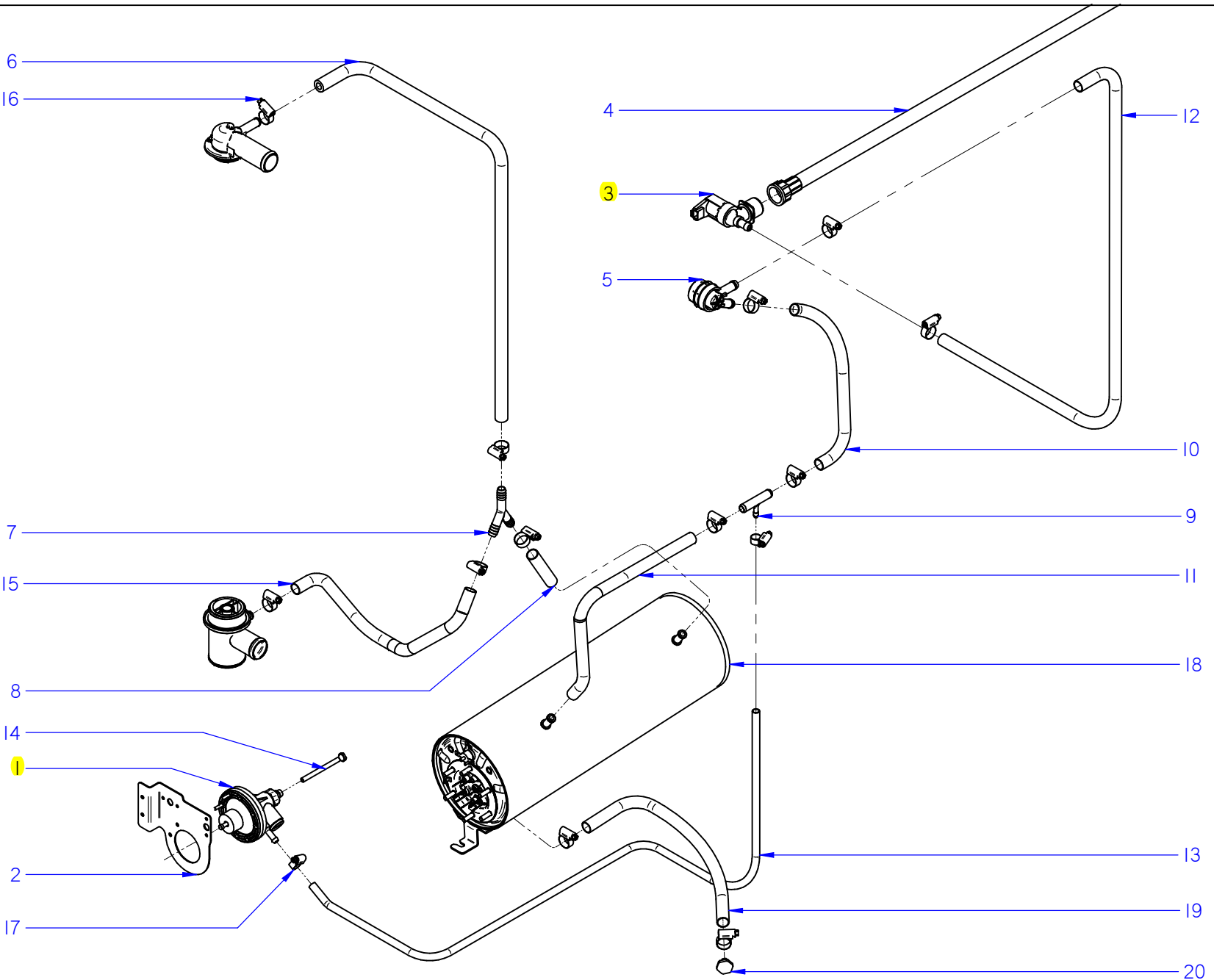

ITEM MARCADO EN COLOR = REPUESTO RECOMENDADO
 COLOURED ITEM = RECOMMENDED SPARE PART

N.º plano / Drawing N.	Firma / Signature	Fecha / Date	Aparato / Appliance	ACABADO / FINISHING PART	Lamina / Sheet	Fogor Industrial S. Coop. FAGOR Oparte
C-3346	Iban R.	2014-12	LAVAVAJILLAS	CO-502 DISHWASHER	5	

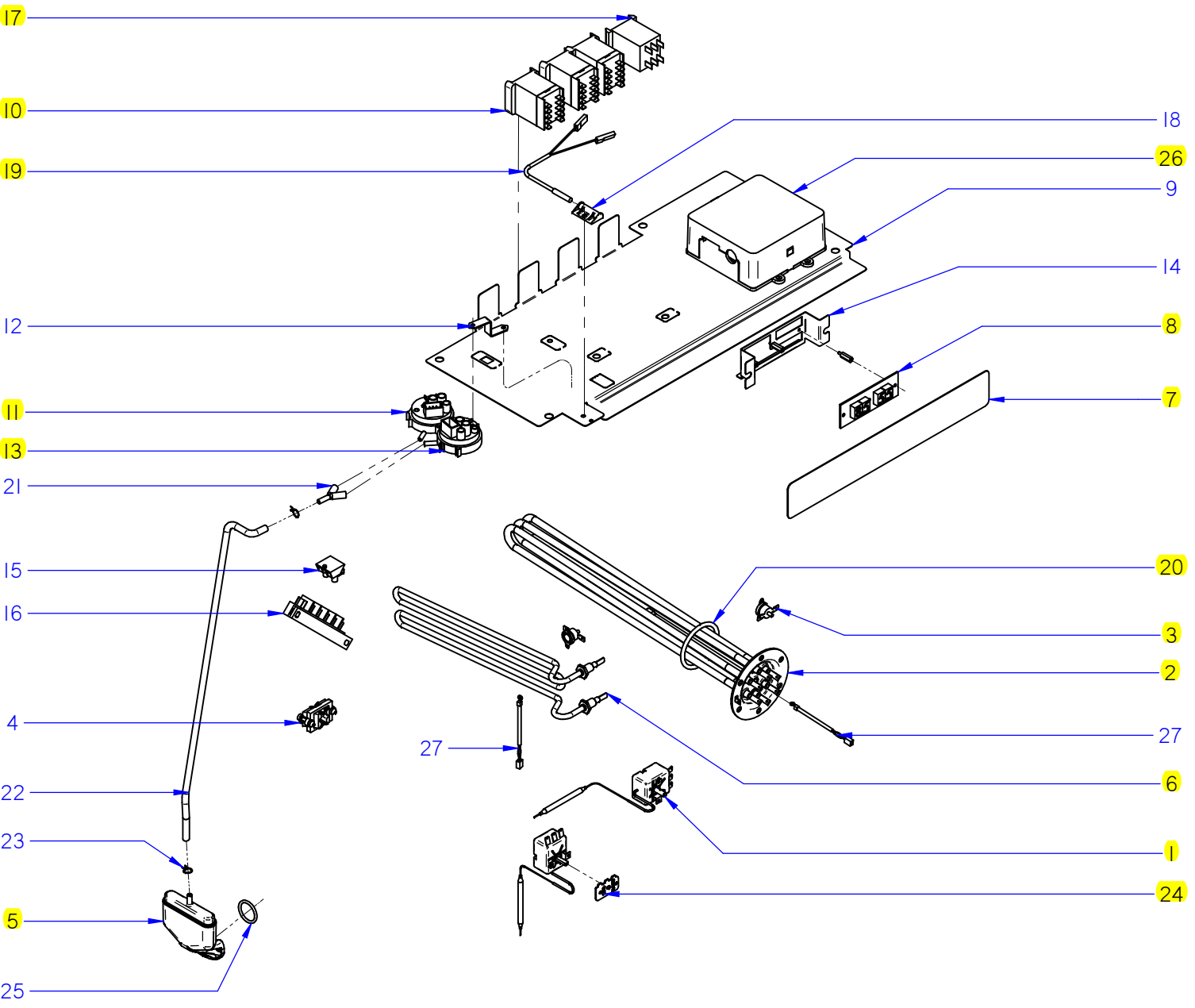

ITEM MARCADO EN COLOR = REPUESTO RECOMENDADO
 COLOURED ITEM = RECOMMENDED SPARE PART

N.º plano / Drawing N.º	Firma / Signature	Fecha / Date	Aparato / Appliance	Lamina	Fagor Industrial S. Coop. FAGOR
C-3347	Iban R.	2014-12	LAVAVAJILLAS CO-502 DISHWASHER	6	Fagor Industrial S. Coop. FAGOR
			CONJUNTO ELECTRICO / ELECTRICAL PART		

CO, COP 504 W

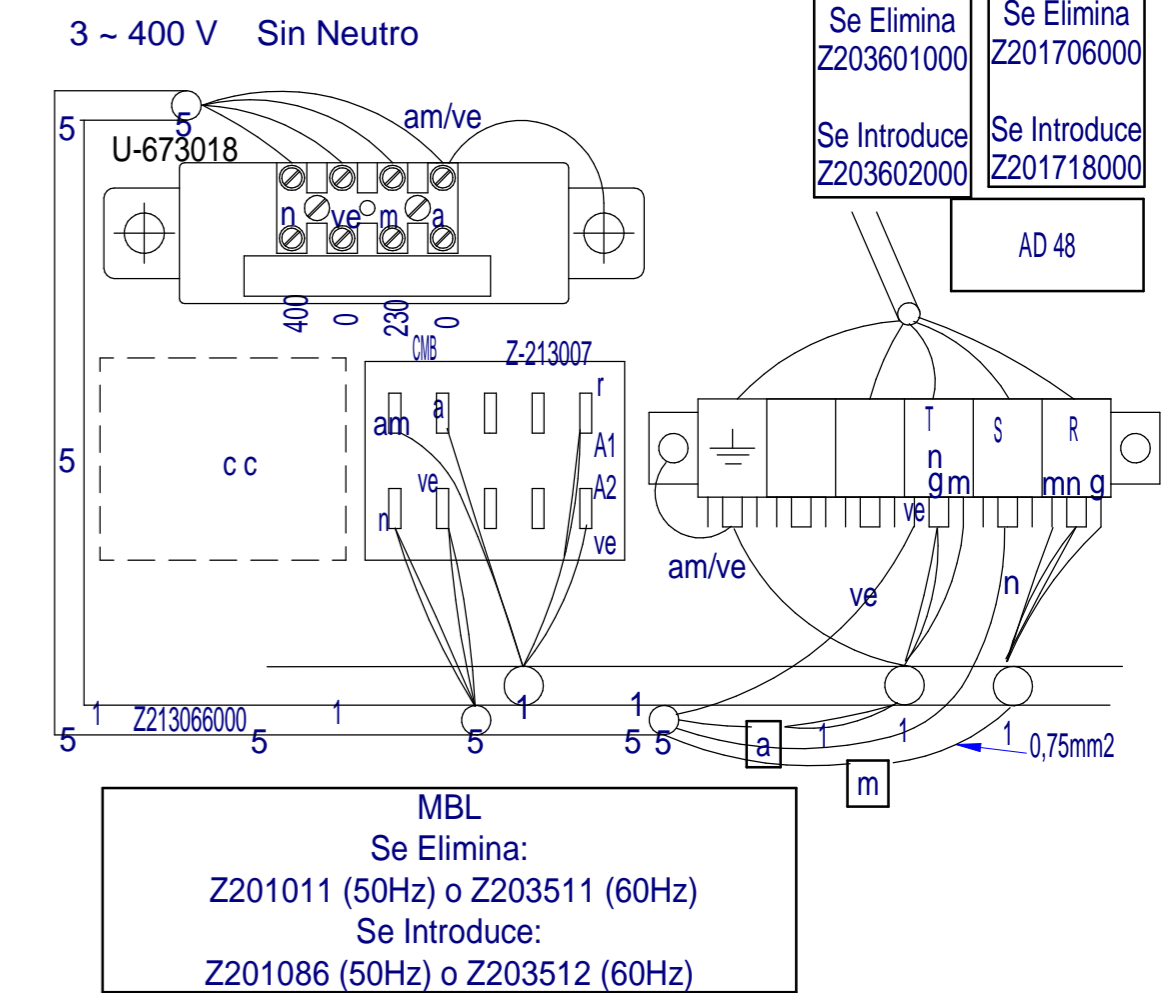
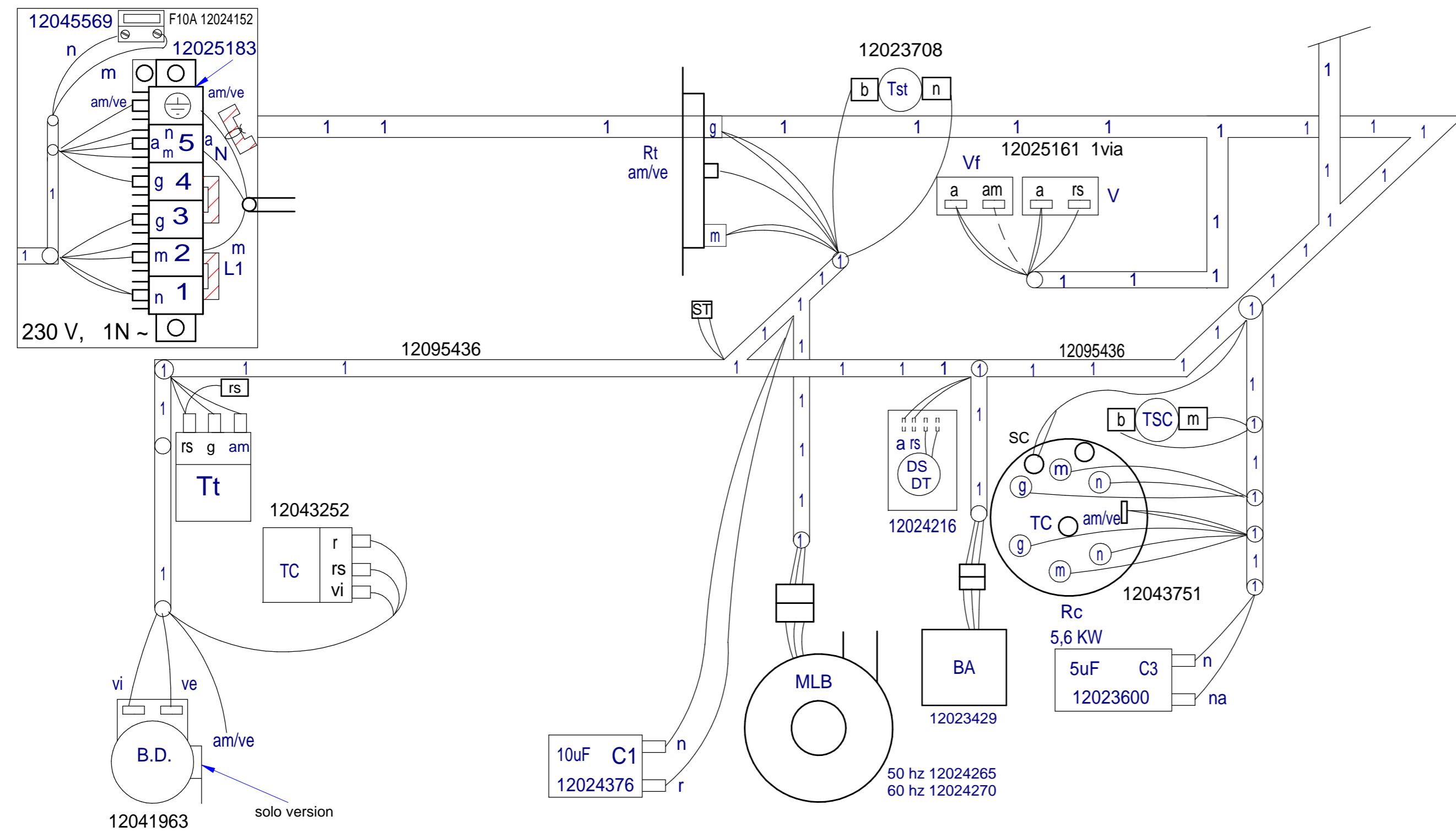
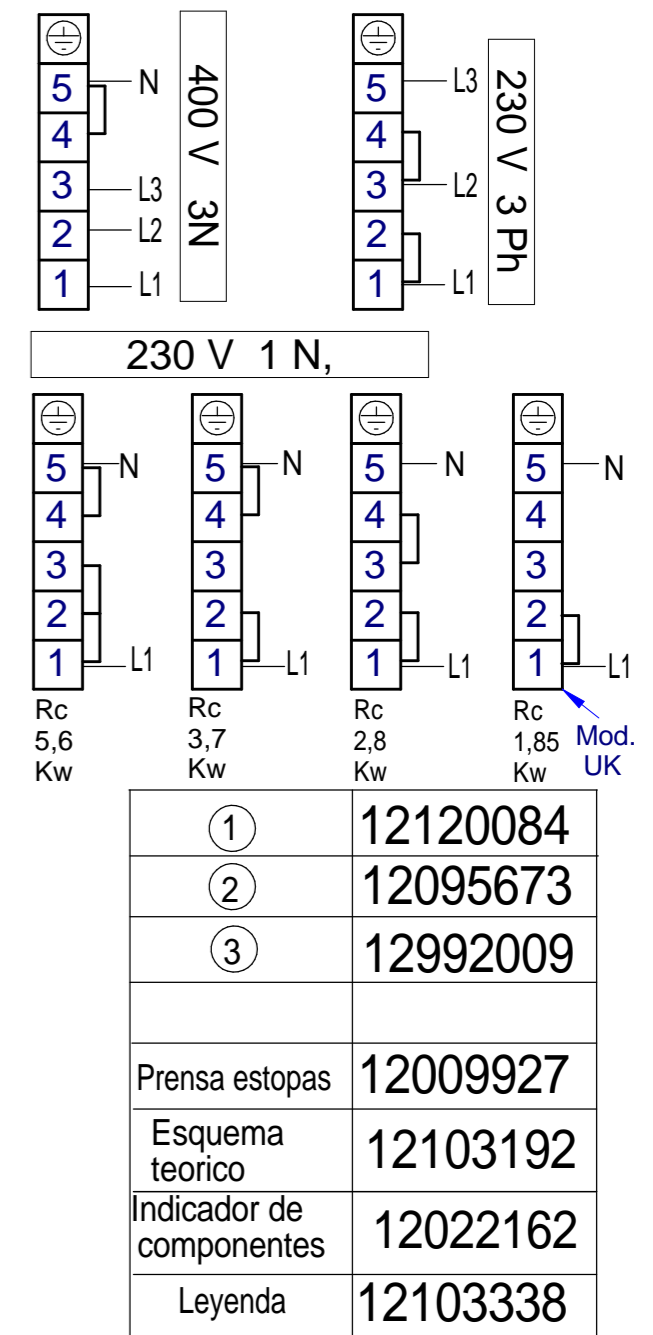
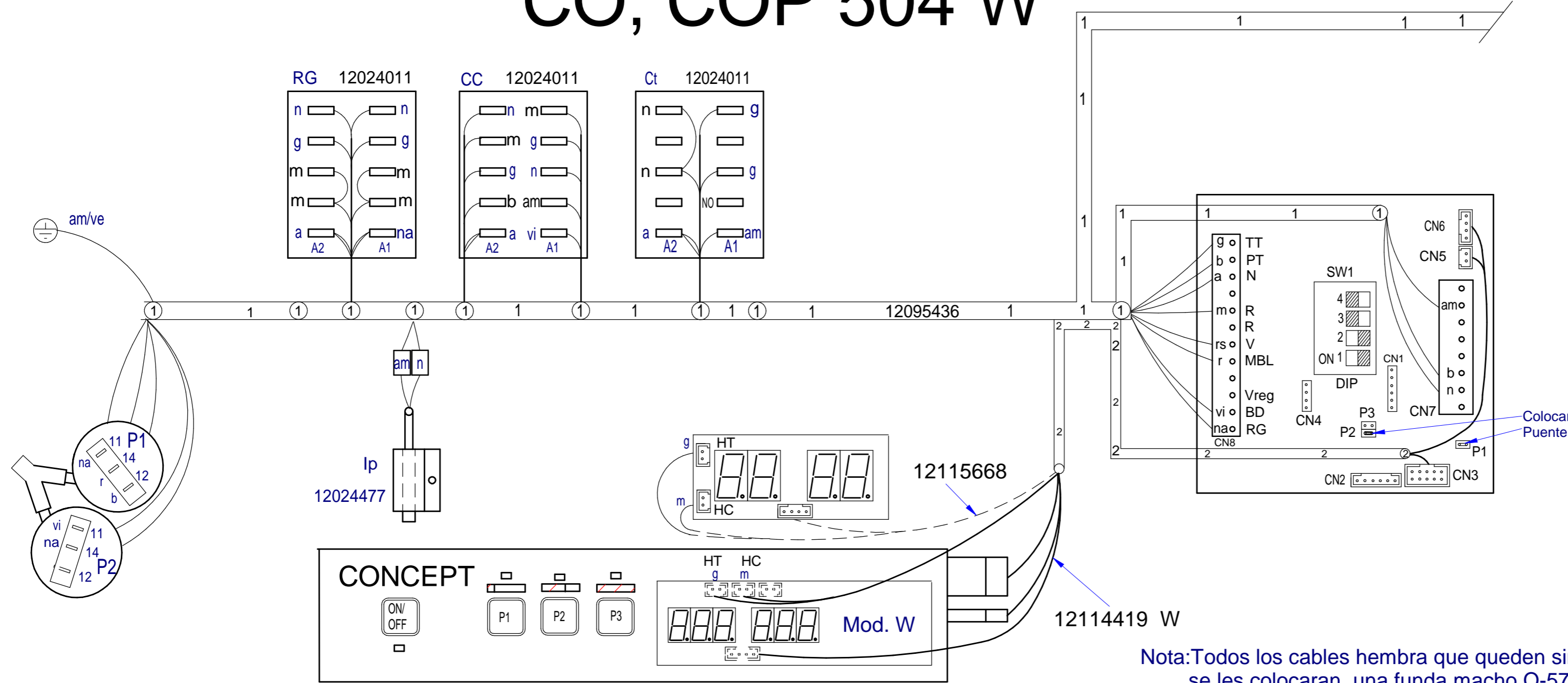

Plano Montaje CO, COP 504 W (64 W)		12114492																																																																																									
Nº	TITLE	QTY	CODE																																																																																								
GENERAL TOLERANCES: ISO 2768-1 Very Coarse																																																																																											
<table border="1"> <tr> <th>LINEAL</th> <th>FINES</th> <th>MEDIO</th> <th>GRUESO</th> <th>GRUESO MUY</th> <th>GRUESO MUY</th> <th>ANGULO</th> <th>FINES</th> <th>MEDIO</th> <th>GRUESO</th> <th>GRUESO MUY</th> </tr> <tr> <td>-0.2mm</td> <td>±0.05</td> <td>±0.10</td> <td>±0.15</td> <td>±0.20</td> <td>±0.30</td> <td>±1°</td> <td>±1°</td> <td>±1°</td> <td>±1°</td> <td>±2°</td> </tr> <tr> <td>3-6mm</td> <td>±0.05</td> <td>±0.10</td> <td>±0.15</td> <td>±0.20</td> <td>±0.30</td> <td>±1°</td> <td>±1°</td> <td>±1°</td> <td>±1°</td> <td>±2°</td> </tr> <tr> <td>6-30mm</td> <td>±0.10</td> <td>±0.20</td> <td>±0.30</td> <td>±0.40</td> <td>±0.60</td> <td>±1°</td> <td>±1°</td> <td>±1°</td> <td>±1°</td> <td>±2°</td> </tr> <tr> <td>30-120mm</td> <td>±0.15</td> <td>±0.30</td> <td>±0.40</td> <td>±0.60</td> <td>±1.00</td> <td>±1°</td> <td>±1°</td> <td>±1°</td> <td>±1°</td> <td>±2°</td> </tr> <tr> <td>120-400mm</td> <td>±0.20</td> <td>±0.40</td> <td>±0.60</td> <td>±1.00</td> <td>±1.50</td> <td>±1°</td> <td>±1°</td> <td>±1°</td> <td>±1°</td> <td>±2°</td> </tr> <tr> <td>400-1000mm</td> <td>±0.30</td> <td>±0.60</td> <td>±1.00</td> <td>±1.50</td> <td>±2.00</td> <td>±1°</td> <td>±1°</td> <td>±1°</td> <td>±1°</td> <td>±2°</td> </tr> <tr> <td>1000-2000mm</td> <td>±0.50</td> <td>±1.00</td> <td>±1.50</td> <td>±2.00</td> <td>±3.00</td> <td>±1°</td> <td>±1°</td> <td>±1°</td> <td>±1°</td> <td>±2°</td> </tr> </table>				LINEAL	FINES	MEDIO	GRUESO	GRUESO MUY	GRUESO MUY	ANGULO	FINES	MEDIO	GRUESO	GRUESO MUY	-0.2mm	±0.05	±0.10	±0.15	±0.20	±0.30	±1°	±1°	±1°	±1°	±2°	3-6mm	±0.05	±0.10	±0.15	±0.20	±0.30	±1°	±1°	±1°	±1°	±2°	6-30mm	±0.10	±0.20	±0.30	±0.40	±0.60	±1°	±1°	±1°	±1°	±2°	30-120mm	±0.15	±0.30	±0.40	±0.60	±1.00	±1°	±1°	±1°	±1°	±2°	120-400mm	±0.20	±0.40	±0.60	±1.00	±1.50	±1°	±1°	±1°	±1°	±2°	400-1000mm	±0.30	±0.60	±1.00	±1.50	±2.00	±1°	±1°	±1°	±1°	±2°	1000-2000mm	±0.50	±1.00	±1.50	±2.00	±3.00	±1°	±1°	±1°	±1°	±2°
LINEAL	FINES	MEDIO	GRUESO	GRUESO MUY	GRUESO MUY	ANGULO	FINES	MEDIO	GRUESO	GRUESO MUY																																																																																	
-0.2mm	±0.05	±0.10	±0.15	±0.20	±0.30	±1°	±1°	±1°	±1°	±2°																																																																																	
3-6mm	±0.05	±0.10	±0.15	±0.20	±0.30	±1°	±1°	±1°	±1°	±2°																																																																																	
6-30mm	±0.10	±0.20	±0.30	±0.40	±0.60	±1°	±1°	±1°	±1°	±2°																																																																																	
30-120mm	±0.15	±0.30	±0.40	±0.60	±1.00	±1°	±1°	±1°	±1°	±2°																																																																																	
120-400mm	±0.20	±0.40	±0.60	±1.00	±1.50	±1°	±1°	±1°	±1°	±2°																																																																																	
400-1000mm	±0.30	±0.60	±1.00	±1.50	±2.00	±1°	±1°	±1°	±1°	±2°																																																																																	
1000-2000mm	±0.50	±1.00	±1.50	±2.00	±3.00	±1°	±1°	±1°	±1°	±2°																																																																																	
GENERAL TOLERANCE FOR FORM AND POSITION: ISO 2768-2																																																																																											
LAVAVAJILLAS		DESIGNED BY: M.Maillou																																																																																									
12114492		VALIDATED BY: A.G.																																																																																									
PROPOSED BY: -		DATE: 12.06.2014																																																																																									
REVISION		SHEET: 1 / 1																																																																																									
		SCALE: 1:1																																																																																									

CO-502, COP-504

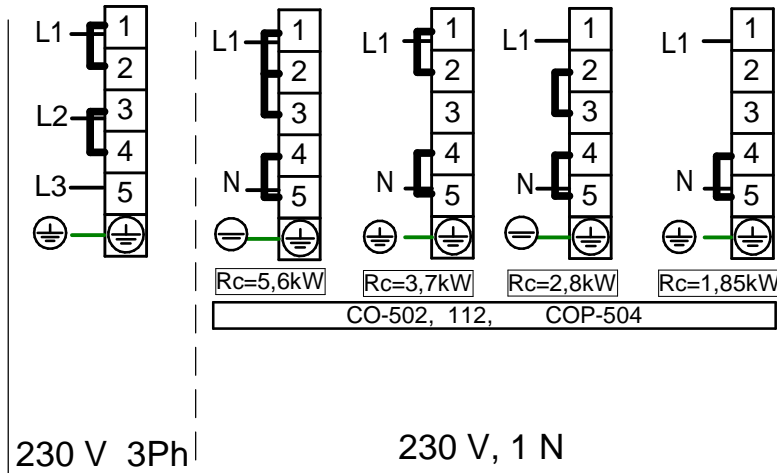
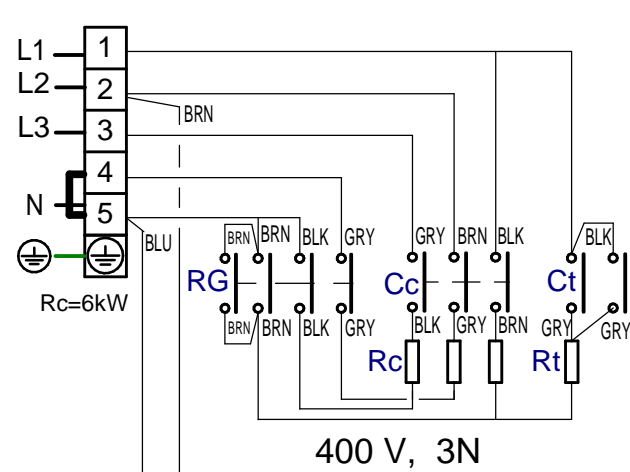

CO 112, 172, COP-174

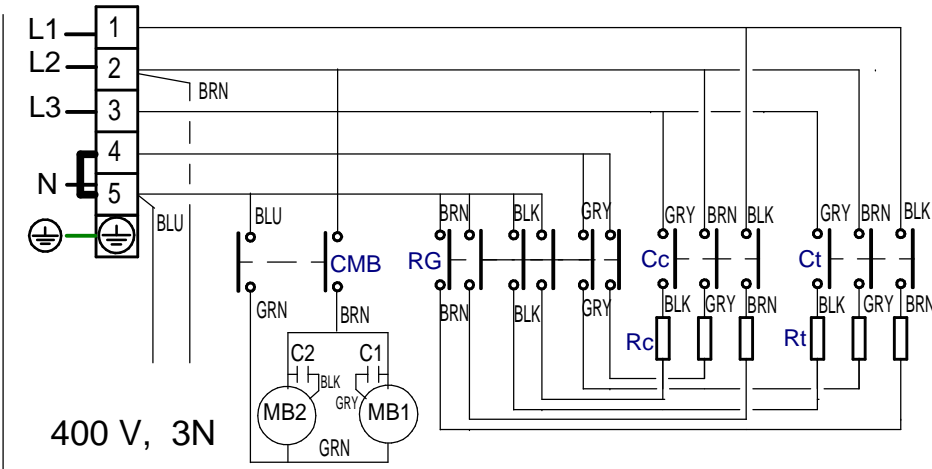

CO 352, 402

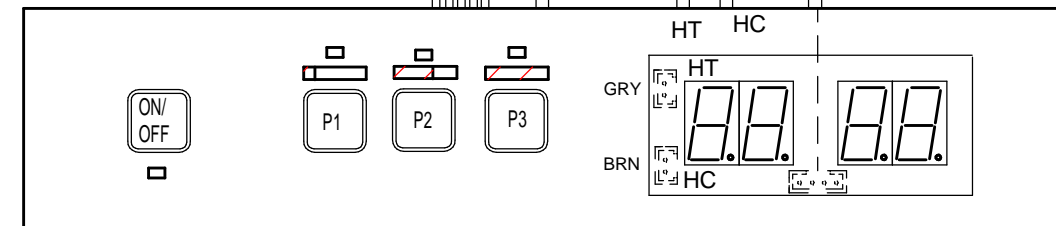
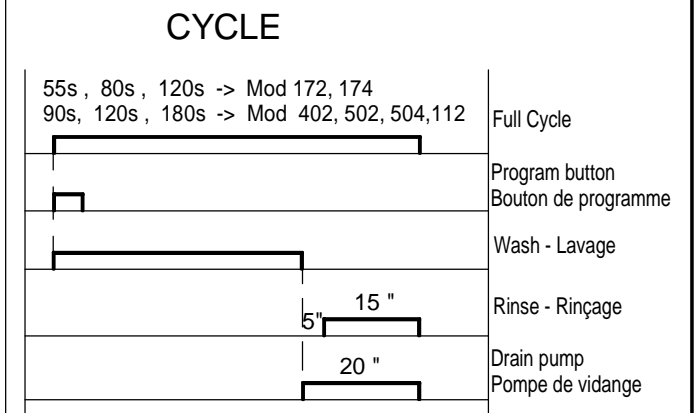
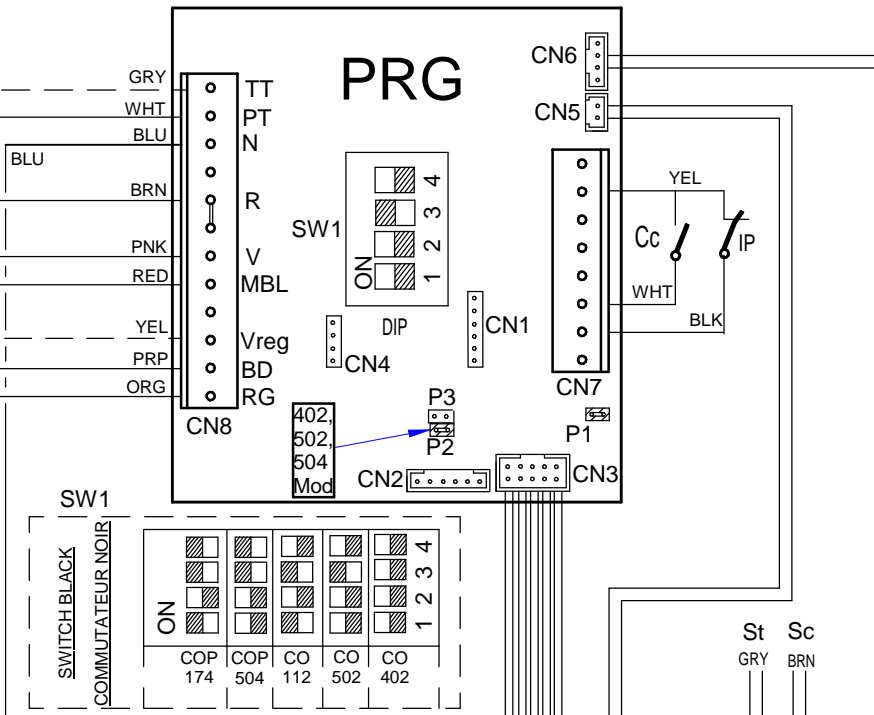
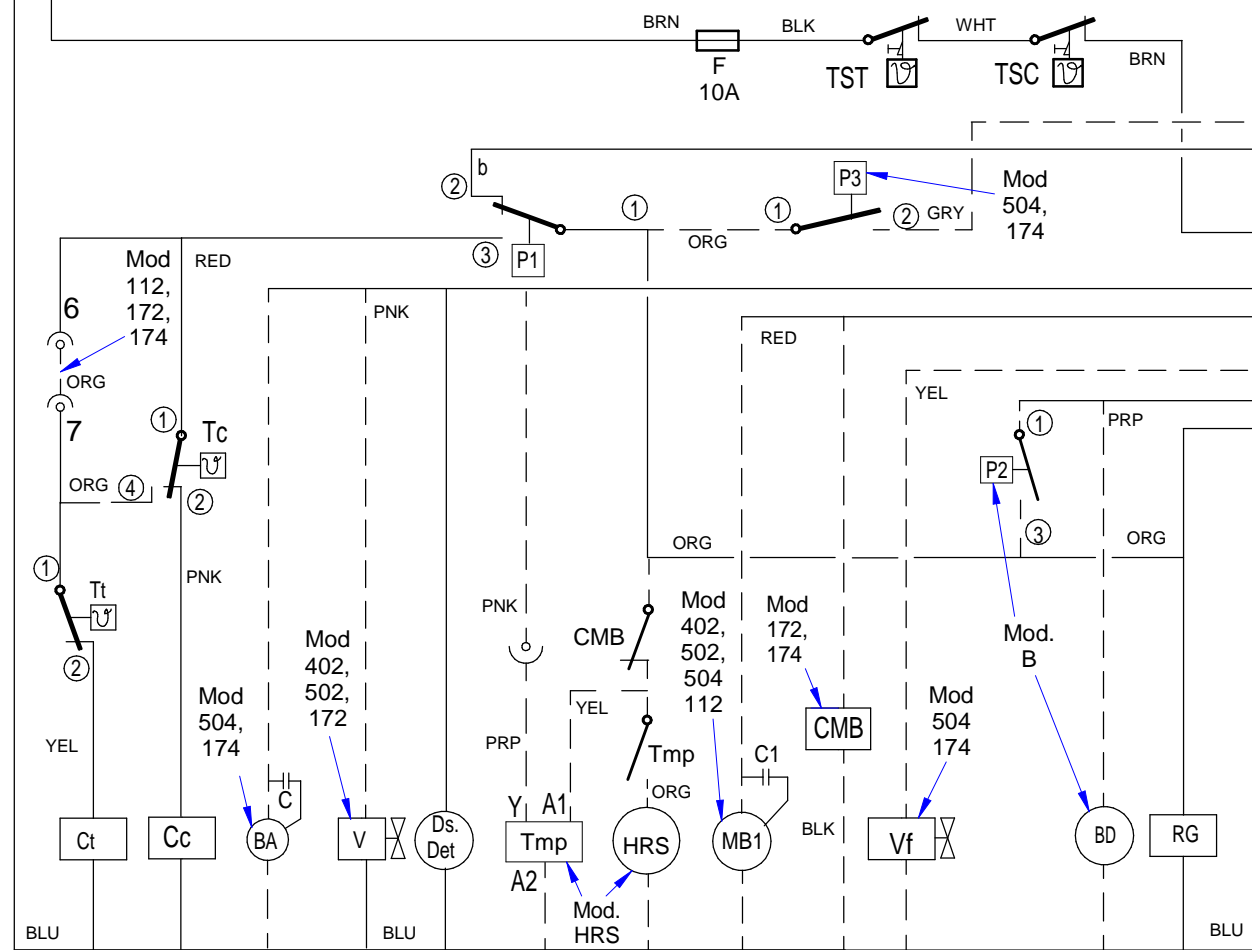
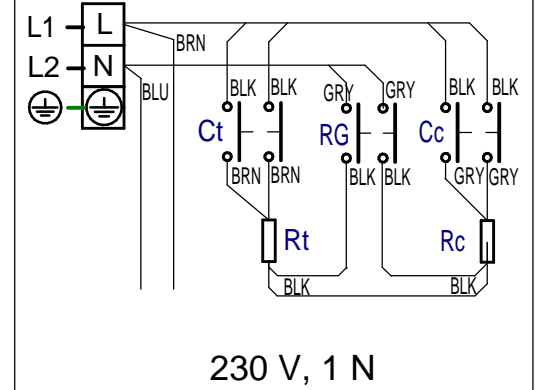

12121300

-	Esquema Teorico CO XX2, COP XX4,	-	12121300																																																																								
Nº	TITLE	QTY	CODE	MATERIAL	TREATMENT																																																																						
GENERAL TOLERANCES:		ISO 2768-1		Very Coarse																																																																							
<table border="1"> <tr> <th></th> <th>Fine</th> <th>Medium</th> <th>Coarse</th> <th>Very Coarse</th> </tr> <tr> <td><3mm</td> <td>±0.05</td> <td>±0.10</td> <td>±0.15</td> <td>±0.20</td> </tr> <tr> <td>3-6mm</td> <td>±0.05</td> <td>±0.10</td> <td>±0.20</td> <td>±0.30</td> </tr> <tr> <td>6-30mm</td> <td>±0.10</td> <td>±0.20</td> <td>±0.50</td> <td>±1.00</td> </tr> <tr> <td>30-120mm</td> <td>±0.15</td> <td>±0.30</td> <td>±0.80</td> <td>±1.20</td> </tr> <tr> <td>120-400mm</td> <td>±0.20</td> <td>±0.50</td> <td>±1.20</td> <td>±2.00</td> </tr> <tr> <td>400-1000mm</td> <td>±0.30</td> <td>±0.80</td> <td>±2.00</td> <td>±3.00</td> </tr> <tr> <td>1000-2000mm</td> <td>±0.50</td> <td>±1.20</td> <td>±3.00</td> <td>±5.00</td> </tr> </table>			Fine	Medium	Coarse	Very Coarse	<3mm	±0.05	±0.10	±0.15	±0.20	3-6mm	±0.05	±0.10	±0.20	±0.30	6-30mm	±0.10	±0.20	±0.50	±1.00	30-120mm	±0.15	±0.30	±0.80	±1.20	120-400mm	±0.20	±0.50	±1.20	±2.00	400-1000mm	±0.30	±0.80	±2.00	±3.00	1000-2000mm	±0.50	±1.20	±3.00	±5.00	<table border="1"> <tr> <th></th> <th>Fine</th> <th>Medium</th> <th>Coarse</th> <th>Very Coarse</th> </tr> <tr> <td><10mm</td> <td>±1°</td> <td>±1°30'</td> <td>±2°</td> <td>±3°</td> </tr> <tr> <td>10-50mm</td> <td>±30'</td> <td>±1°</td> <td>±1°</td> <td>±1°</td> </tr> <tr> <td>50-120mm</td> <td>±20'</td> <td>±30'</td> <td>±30'</td> <td>±1°</td> </tr> <tr> <td>120-400mm</td> <td>±10'</td> <td>±15'</td> <td>±30'</td> <td>±1°</td> </tr> <tr> <td>>400mm</td> <td>±5'</td> <td>±10'</td> <td>±20'</td> <td>±1°</td> </tr> </table>			Fine	Medium	Coarse	Very Coarse	<10mm	±1°	±1°30'	±2°	±3°	10-50mm	±30'	±1°	±1°	±1°	50-120mm	±20'	±30'	±30'	±1°	120-400mm	±10'	±15'	±30'	±1°	>400mm	±5'	±10'	±20'	±1°		
	Fine	Medium	Coarse	Very Coarse																																																																							
<3mm	±0.05	±0.10	±0.15	±0.20																																																																							
3-6mm	±0.05	±0.10	±0.20	±0.30																																																																							
6-30mm	±0.10	±0.20	±0.50	±1.00																																																																							
30-120mm	±0.15	±0.30	±0.80	±1.20																																																																							
120-400mm	±0.20	±0.50	±1.20	±2.00																																																																							
400-1000mm	±0.30	±0.80	±2.00	±3.00																																																																							
1000-2000mm	±0.50	±1.20	±3.00	±5.00																																																																							
	Fine	Medium	Coarse	Very Coarse																																																																							
<10mm	±1°	±1°30'	±2°	±3°																																																																							
10-50mm	±30'	±1°	±1°	±1°																																																																							
50-120mm	±20'	±30'	±30'	±1°																																																																							
120-400mm	±10'	±15'	±30'	±1°																																																																							
>400mm	±5'	±10'	±20'	±1°																																																																							
GENERAL TOLERANCE FOR FORM AND POSITION: ISO 2768-2		LAVAVAJILLAS		DESIGNED BY	VALIDATED BY																																																																						
				M.Maillo	A.gallastegui																																																																						
				DATE	19.01.2015																																																																						
				SHEET:	1 / 1																																																																						
				SCALE:	1:1																																																																						
12121300		REVISION		PROPOSED BY: -																																																																							
				ISSUE DATE:																																																																							

